

INTERCONNECTS

SERIES 860 & 861 • 1mm GRID HEADERS AND SOCKETS • SINGLE ROW STRIPS

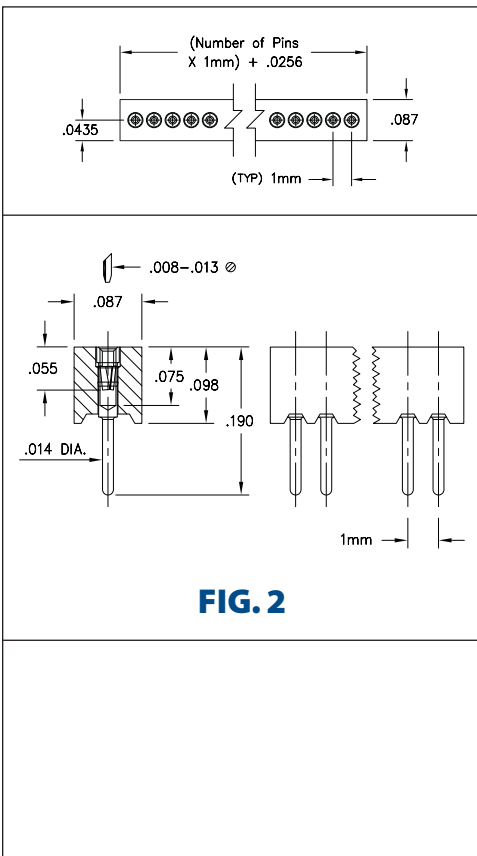

- Series 860 headers and Series 861 sockets are single row, 1mm pitch interconnects rated at 2 amps
- Series 860 headers have .015" diameter solder tails and .011" diameter pluggable pins (MM #3039) See page 208 for details
- Series 861 sockets have .014" diameter solder tails (MM #0439). See page 156 for details
- Both 860 headers and 861 sockets are available in 2-50 position strips
- The header and socket provide a mated height of .196" for board stacking applications
- Insulators are high temperature thermoplastic, suitable for most soldering processes, and feature standoffs to promote solder flow

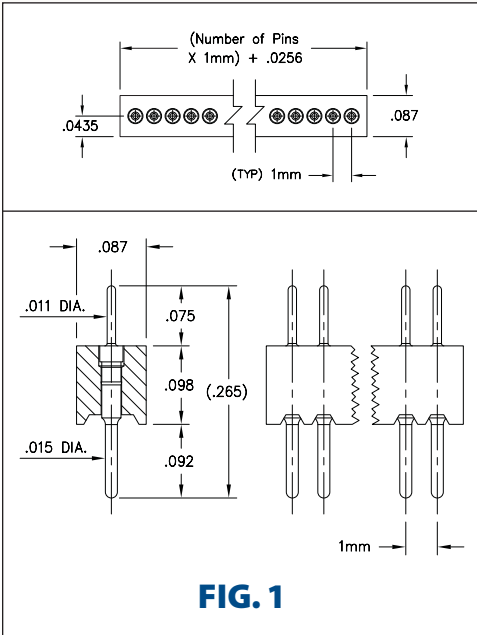
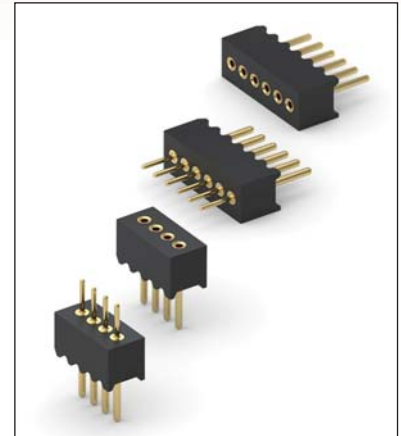

ORDERING INFORMATION

FIG. 1	Series 860...002	Single Row 1mm Header			
		860-10-0	-10-002000		
	Specify number of pins		02-50		
	RoHS-2 2011/65/EU	XX=Plating Code See Below	For Electrical, Mechanical & Environmental Data, See page 264		
	SPECIFY PLATING CODE XX=	10			
	Pin Plating	10 μ" Au			

FIG. 2	Series 861...002	Single Row 1mm Socket			
		861-13-0	-10-002000		
	Specify number of pins		02-50		
	RoHS-2 2011/65/EU	XX=Plating Code See Below	For Electrical, Mechanical & Environmental Data, See page 264		
	SPECIFY PLATING CODE XX=	13			
	Sleeve (Pin)	10 μ" Au			
	Contact (Clip)	30 μ" Au			

INTERCONNECTS

SERIES 850, 851, 852, 853 • .050" GRID HEADERS AND SOCKETS • SINGLE AND DOUBLE ROW STRIPS

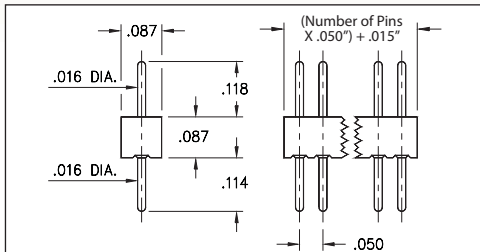

FIG. 1

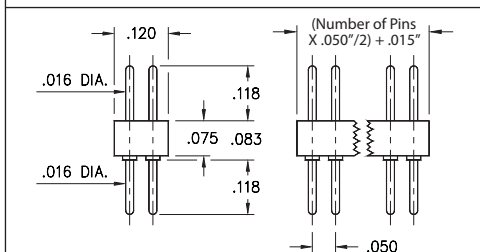

FIG. 2

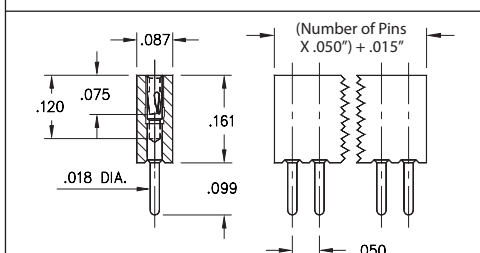

FIG. 3

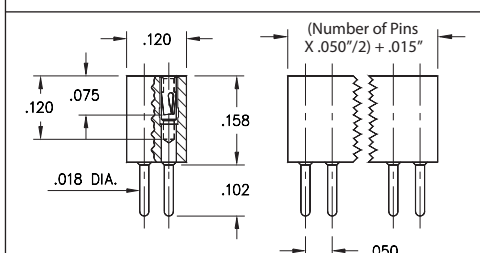

FIG. 4

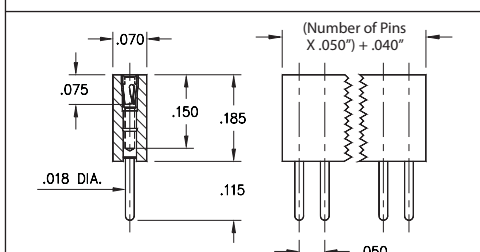
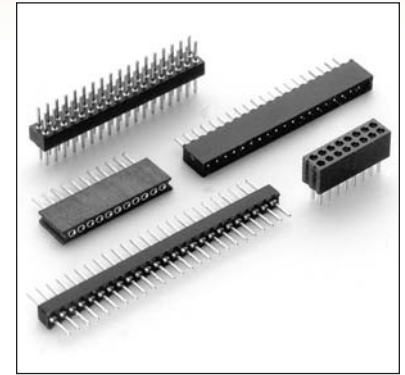















FIG. 5

- Series 850, 851, 852, 853 single and double row interconnects have .050" pin spacing and permit board stacking as low as .248"
- Pin headers have .016" dia. pins (MM #4006-0) See page 208 for details
- MM #0467 and MM #4890 receptacles use Hi-Rel, 3-finger BeCu #11 contact rated at 3 amps. (#11 contact accepts pin diameters from .015"-.020"). See pages 158 and 160 for details
- Insulators are high temperature thermoplastic, suitable for all soldering operations



ORDERING INFORMATION

FIG. 1	Series 850...001	Single Row .087" Profile Pin Header			
		850-XX-0__-10-001000 Specify number of pins → 01-50			
FIG. 2	Series 852...001	Double Row .083" Profile Pin Header			
		852-XX-__-10-001000 Specify number of pins → 002-100			
					
SPECIFY PLATING CODE XX=		10 	90	40 	
Pin Plating 		10 μ" Au	200 μ" Sn/Pb	200 μ" Sn	
FIG. 3	Series 851...001	Single Row .161" Profile Socket			
		851-XX-0__-10-001000 Specify number of pins → 01-50			
FIG. 4	Series 853...001	Double Row .161" Profile Socket			
		853-XX-__-10-001000 Specify number of pins → 002-100			
FIG. 5	Series 851...002	Single Row .185" Profile Socket			
		851-XX-0__-10-002000 Specify number of pins → 01-77			
					
SPECIFY PLATING CODE XX=			91	93	99
Sleeve (Pin) 			200 μ" Sn/Pb	200 μ" Sn/Pb	200 μ" Sn/Pb
Contact (Clip) 			10 μ" Au	30 μ" Au	100 μ" Sn/Pb
				41 	43 
				200 μ" Sn	200 μ" Sn
				10 μ" Au	30 μ" Au



INTERCONNECTS

SERIES 851 & 853 • .050" GRID LONG TAIL SOCKETS • SINGLE AND DOUBLE ROW STRIPS

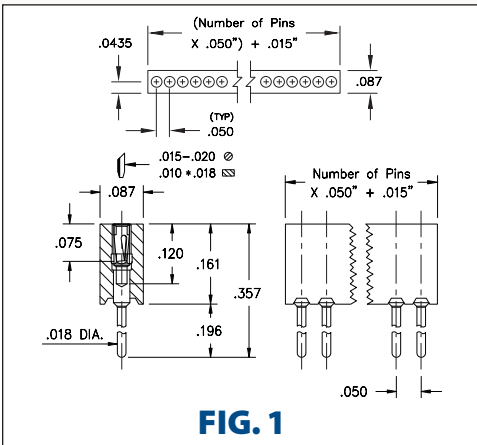

FIG. 1

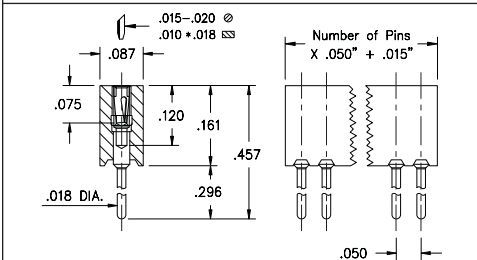

FIG. 2

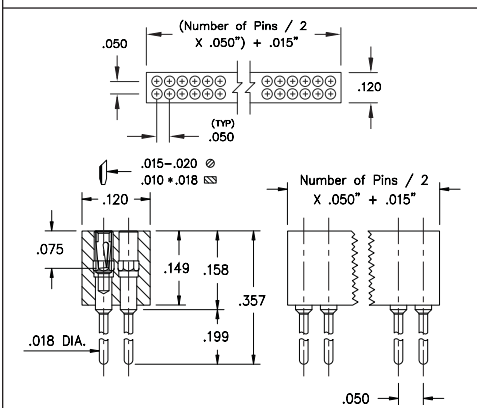

FIG. 3

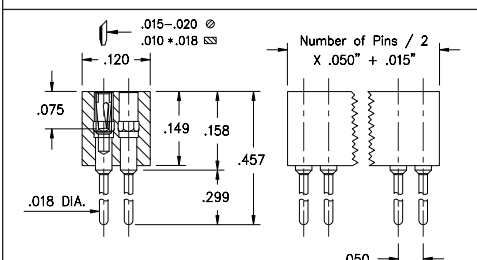
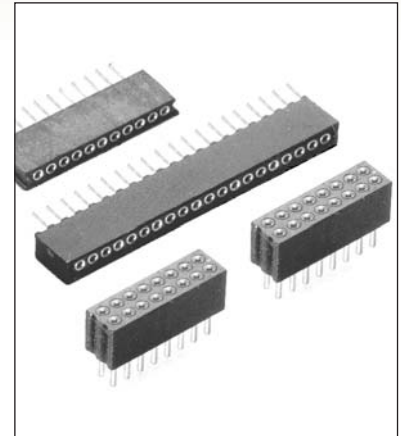

FIG. 4

- Series 851...011 and 853...011 use MM #4890-1 pins. See page 160 for details
- Series 851...021 and 853...021 use MM #4890-2 pins. See page 160 for details
- Receptacles use Hi-Rel, 3-finger BeCu #11 contact rated at 3 amps. (#11 contact accepts pin diameters from .015"-.020"). See page 251 for details
- Insulators are high temperature thermoplastic, suitable for all soldering operations



ORDERING INFORMATION

	Series 851...011	Single Row Socket
FIG. 1	851-XX-0	-10-011000 Specify number of pins 01-50
FIG. 2	Series 851...021	Single Row Socket
FIG. 3	851-XX-0	-10-021000 Specify number of pins 01-50
FIG. 3	Series 853...011	Double Row Socket
FIG. 4	853-XX-	-10-011000 Specify number of pins 004-100
FIG. 4	Series 853...021	Double Row Socket
	853-XX-	-10-021000 Specify number of pins 004-100
<div style="display: flex; justify-content: space-around; align-items: center;"> <div style="border: 1px solid black; padding: 5px; background-color: #90EE90;">RoHS-2 2011/65/EU</div> <div style="border: 1px solid black; border-radius: 50%; padding: 5px;">XX=Plating Code See Below</div> <div style="border: 1px solid black; border-radius: 50%; padding: 5px;">For Electrical, Mechanical & Environmental Data, See page 264</div> </div>		
SPECIFY PLATING CODE XX=		
Sleeve (Pin)		41 43
Contact (Clip)		200 μ" Sn 200 μ" Sn
		10 μ" Au 30 μ" Au

INTERCONNECTS

SERIES 850, 851, 852, 853 • 050" GRID RIGHT ANGLE HEADERS AND SOCKETS • SINGLE AND DOUBLE ROW STRIPS

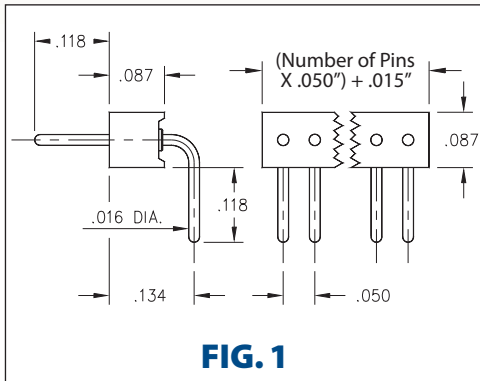

FIG. 1

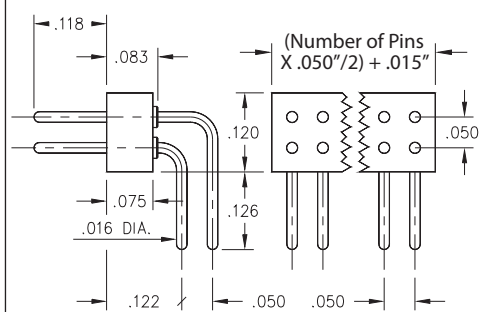

FIG. 2

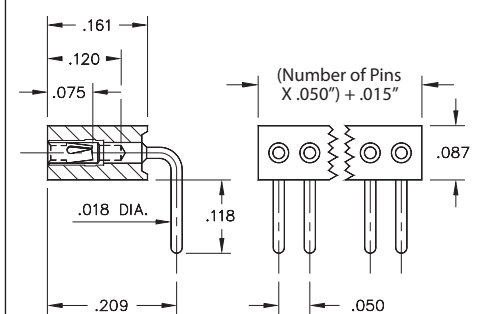

FIG. 3

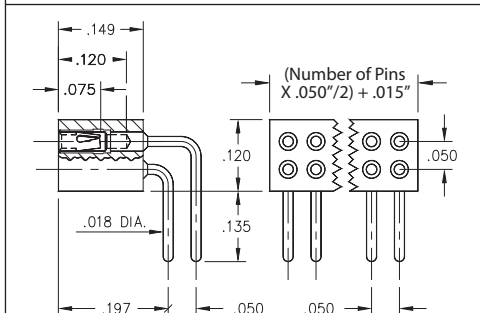
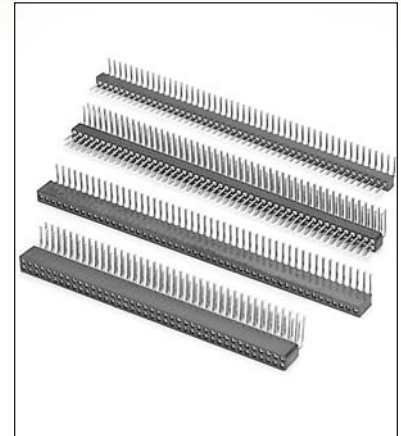

FIG. 4

- Series 850 and 851 interconnects are available in single and double row form
- Series 850 & 852 headers use MM #4006-1 and #4006-2 pins. See page 208 for details
- Series 851 & 853 sockets use MM #4890-1 and #4890-2 receptacles that accept pin diameters from .015"-.021". See page 160 for details
- Receptacles use Hi-Rel, 3-finger BeCu #11 contact rated at 3 amps. See page 251 for details
- Insulators are high temperature thermoplastic, suitable for all soldering operations



ORDERING INFORMATION

FIG. 1	Series 850...001	Single Row Right Angle Pin Header		
	850-XX-0	-20-001000	Specify number of pins 01-50	
FIG. 2	Series 852...001	Double Row Right Angle Pin Header		
	852-XX-	-20-001000	Specify number of pins 002-100	
XX=Plating Code See Below For Electrical, Mechanical & Environmental Data, See page 264				
SPECIFY PLATING CODE XX=		10	90	40
Pin Plating		10 μ" Au	200 μ" Sn/Pb	200 μ" Sn

FIG. 3	Series 851...001	Single Row Right Angle Socket			
	851-XX-0	-20-001000	Specify number of pins 01-50		
FIG. 4	Series 853...001	Double Row Right Angle Socket			
	853-XX-	-20-001000	Specify number of pins 002-100		
XX=Plating Code See Below For Electrical, Mechanical & Environmental Data, See page 264					
SPECIFY PLATING CODE XX=			93	99	43
Sleeve (Pin)			200 μ" Sn/Pb	200 μ" Sn/Pb	200 μ" Sn
Contact (Clip)			30 μ" Au	100 μ" Sn/Pb	30 μ" Au



INTERCONNECTS

SERIES 850, 851, 852, 853 • 050" GRID SURFACE MOUNT HEADERS AND SOCKETS • SINGLE AND DOUBLE ROW STRIPS

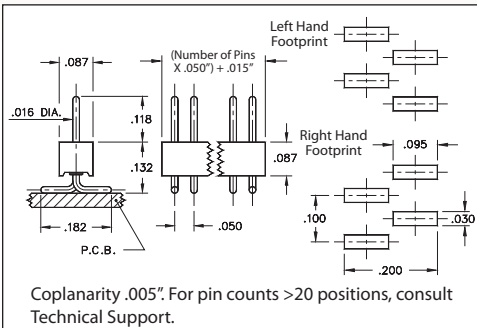

FIG. 1

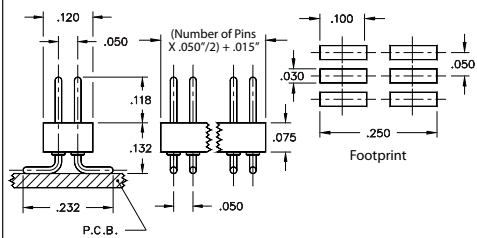

FIG. 2

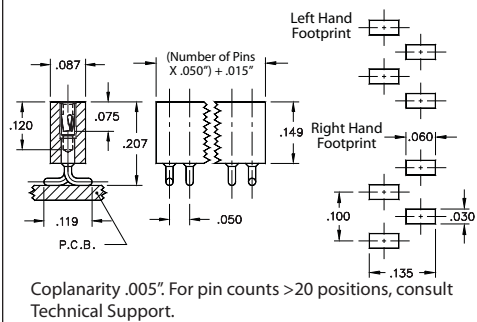

FIG. 3

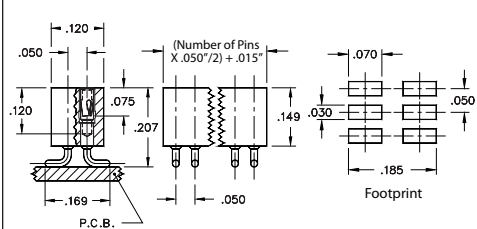
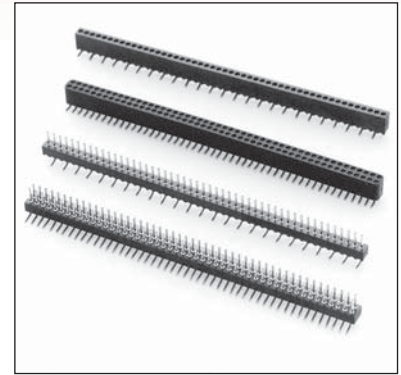

FIG. 4

- Single row interconnects having an even number of pins are now available with a left or right hand footprints
- Headers (850 and 852) use MM #4006 pins. See page 208 for details
- Sockets (851 and 853) use MM #4890-0 receptacles and accept pin diameters from .015"-.021". See page 160 for details
- Receptacles use Hi-Rel, 3-finger BeCu #11 contact rated at 3 amps. See page 251 for details
- Insulators are high temperature thermoplastic, suitable for all soldering operations



ORDERING INFORMATION

FIG. 1L	Single Row Header, Left Hand Footprint, Odd or Even # of Pins						
	850-XX-0__-30-001000 Specify number of pins ↑ 02-50						
FIG. 1R	Single Row Header, Right Hand Footprint, Even # of Pins						
	850-XX-0__-30-002000 Specify number of pins ↑ 02-50						
FIG. 2	Double Row Header, Even # of Pins						
	852-XX-__-30-001000 Specify number of pins ↑ 004-100						
SPECIFY PLATING CODE XX=		10 ◆	90	40 ◆			
Pin Plating		10 μ" Au	200 μ" Sn/Pb	200 μ" Sn			
FIG. 3L	Single Row Socket, Left Hand Footprint, Odd or Even # of Pins						
	851-XX-0__-30-001000 Specify number of pins ★ ↑ 02-50						
FIG. 3R	Single Row Socket, Right Hand Footprint, Even # of Pins						
	851-XX-0__-30-002000 Specify number of pins ↑ 02-50						
FIG. 4	Double Row Socket, Even # of Pins						
	853-XX-__-30-001000 Specify number of pins ★ ↑ 004-100						
		XX=Plating Code See Below		<i>For Electrical, Mechanical & Environmental Data, See page 264</i>			
SPECIFY PLATING CODE XX=		91	93	99	41 ◆	43 ◆	44 ◆
Sleeve (Pin)		200 μ" Sn/Pb	200 μ" Sn/Pb	200 μ" Sn/Pb	200 μ" Sn	200 μ" Sn	200 μ" Sn
Contact (Clip)		10 μ" Au	30 μ" Au	100 μ" Sn/Pb	10 μ" Au	30 μ" Au	100 μ" Sn

★ 44 Plating Non-Standard



HORIZONTAL SMT PINS & CONNECTORS

VERSATILE CONNECTORS FOR HORIZONTAL & EDGE BOARD MATING APPLICATIONS

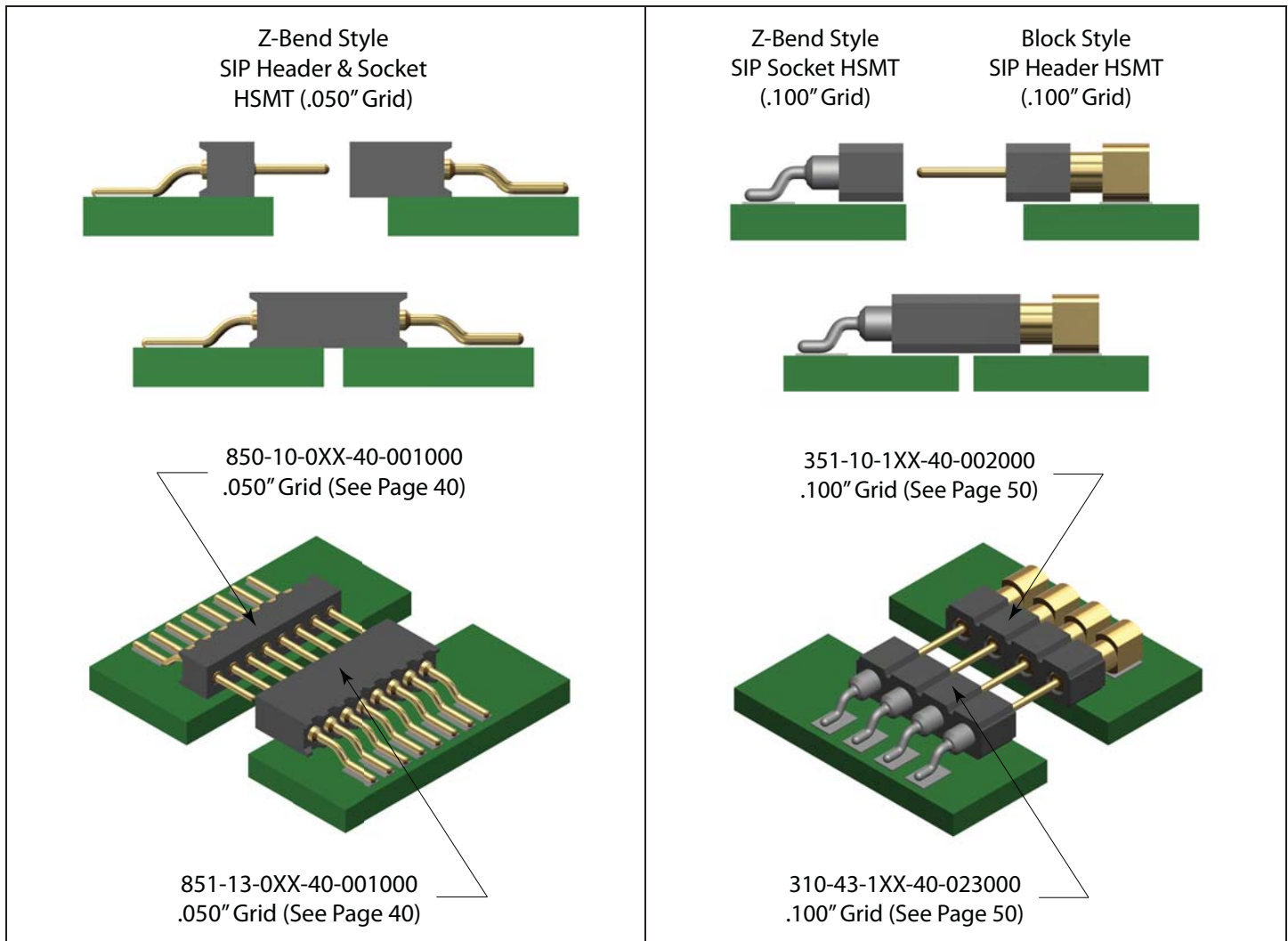

Mill-Max Mfg. offers a complete line of Horizontal Surface Mount products including headers and sockets on .050" (1,27mm) and .100" (2,54mm) grid, discrete spring-loaded and mating target pins and spring-loaded connector strips.

For low profile IO applications surface mount SIP sockets and headers strips are assembled parallel to the board surface. They are ideal for placement near the board edge for easy access test connections & creating pluggable adapter modules which can sit perpendicular to the motherboard (mated to a vertical connector), effectively conserving precious board real estate.



HORIZONTAL SMT PINS & CONNECTORS

VERSATILE CONNECTORS FOR HORIZONTAL & EDGE BOARD MATING APPLICATIONS

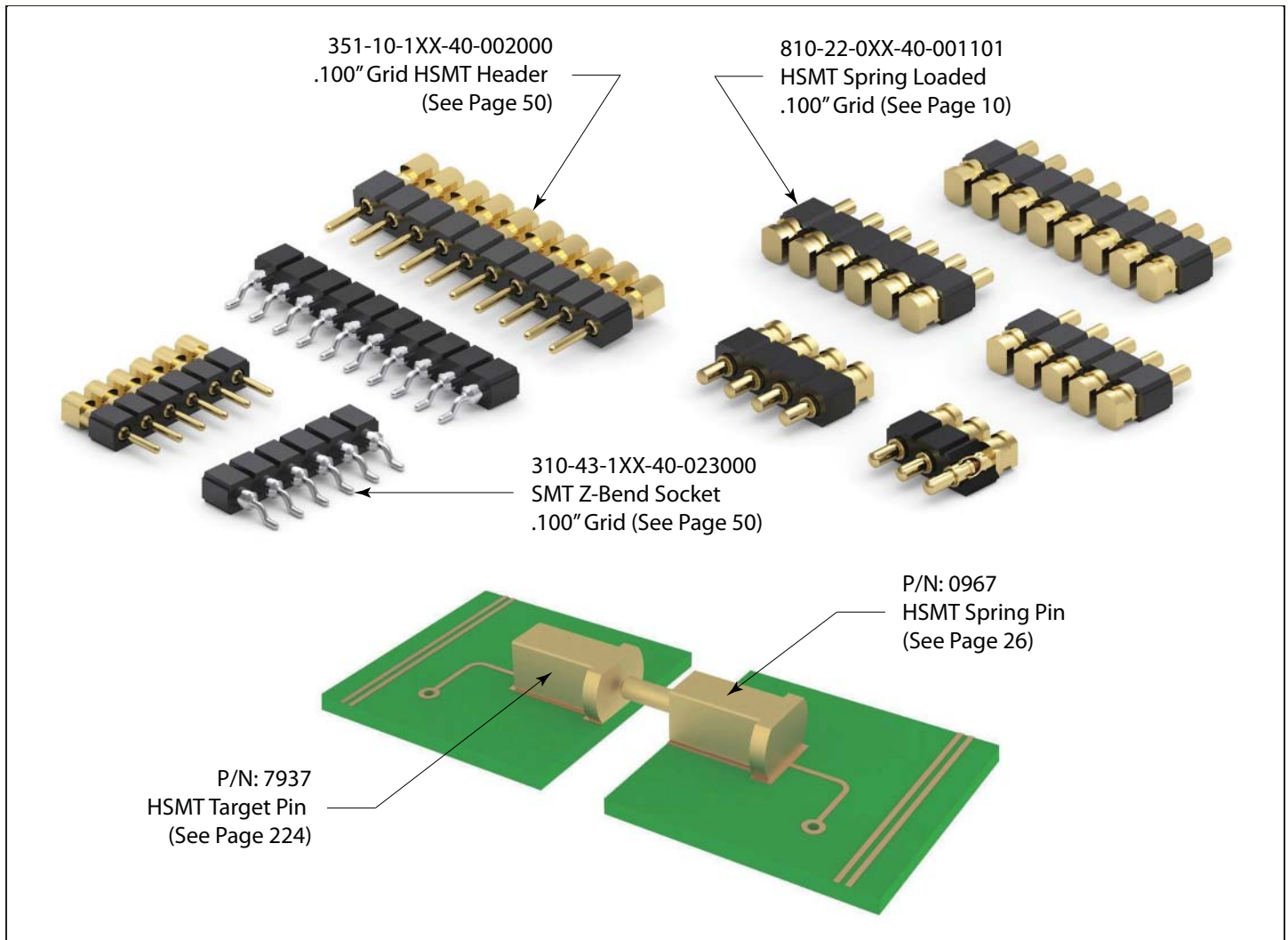

Mill-Max Mfg's #0967 (featured above) is a low profile, horizontal, surface mount spring pin designed for edge board interface applications: board-to-board or device-to-board. The #0967 mounts parallel to the P.C. board so that the plunger travel is horizontal to the board surface. The above board height of .100" (2,54mm) provides a low profile for tight packaging requirements. Typically mounted on the edge of the P.C. board, it can be mated with a board running perpendicular to it, or parallel P.C. boards can be daisy-chained together by using the Mill-Max Mfg. #7937 horizontal SMT target pin and #0967 on opposing boards.



INTERCONNECTS

SERIES 850 & 851 • .050" GRID HORIZONTAL SURFACE MOUNT Z-BEND HEADERS & SOCKETS • SINGLE ROW STRIPS

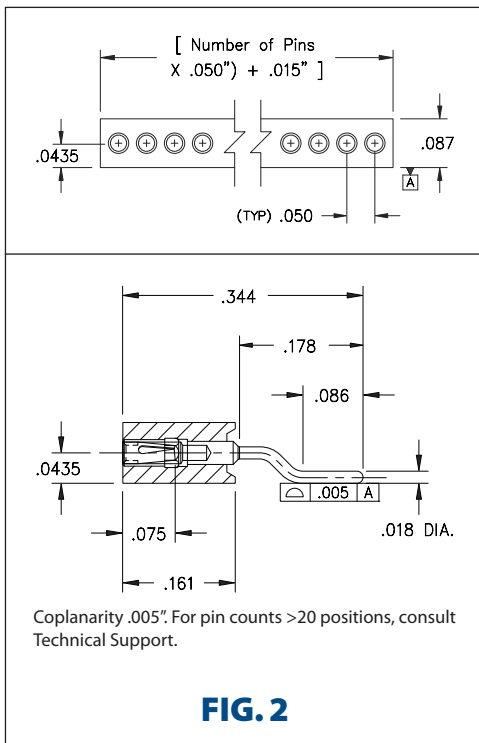
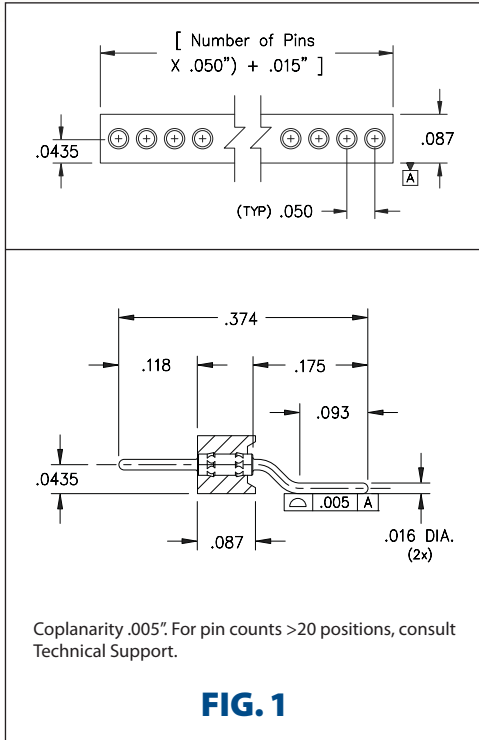

- Series 850 horizontal surface mount headers have .016" dia. pluggable pins and Z-bent tails for SMT soldering to the P.C.B. (MM #4006-1). See page 208 for details
- Series 851 horizontal Surface Mount Z-Bend sockets uses MM #4890-1 receptacles that accept pin diameters from .015"-.020". See page 160 for details
- Receptacles use Hi-Rel, 3-finger BeCu #11 contact rated at 3 amps. See page 251 for details
- Insulators are high temperature thermoplastic, suitable for all soldering operations

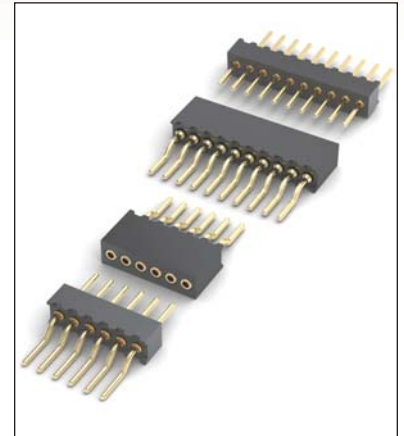

ORDERING INFORMATION

FIG. 1		Series 850...001 Single Row Surface Mount Z-Bend Header					
		850-10-0-40-001000					
		Specify number of pins		02-20			
		RoHS - 2 2011/65/EU		XX=Plating Code See Below		For Electrical, Mechanical & Environmental Data, See page 264	
SPECIFY PLATING CODE XX=		10					
Pin Plating				10 μ" Au			
FIG. 2		Series 851...001 Single Row Surface Mount Z-Bend Socket					
		851-XX-0-40-001000					
		Specify number of pins		02-20			
		RoHS - 2 2011/65/EU		XX=Plating Code See Below		For Electrical, Mechanical & Environmental Data, See page 264	
SPECIFY PLATING CODE XX=		11		13			
Sleeve (Pin)				10 μ" Au		10 μ" Au	
Contact (Clip)				10 μ" Au		30 μ" Au	

INTERCONNECTS

SERIES 340 & 399 • .050" AND .100" GRID SURFACE MOUNT HEADERS & SOCKETS • SINGLE ROW STRIPS

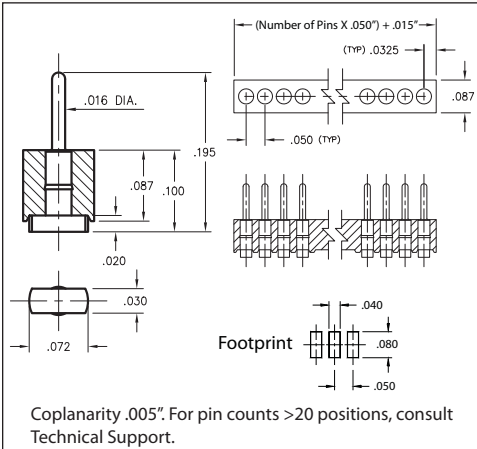

FIG. 1

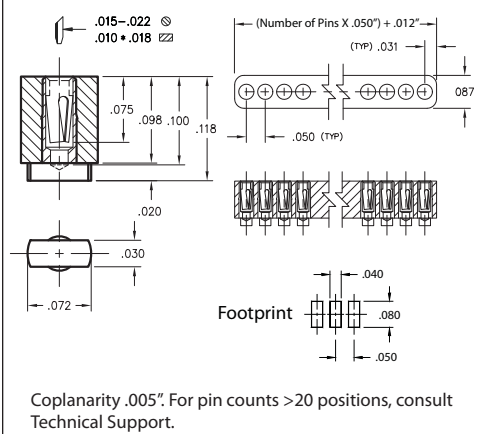

FIG. 2

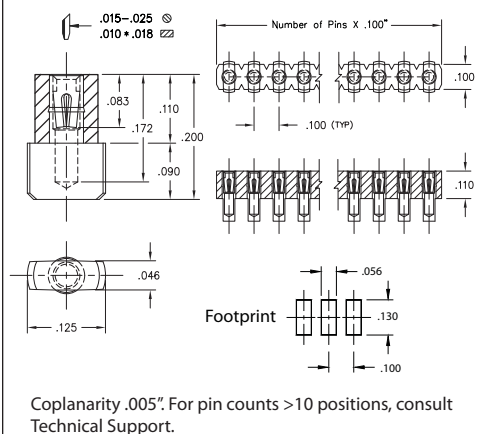

FIG. 3

- Series 340 and 399 interconnects are single row headers & sockets having unique surface mount "block" terminals
- "Block" termination makes the interconnects "self standing". This also minimizes profile and reduces the footprint compared with traditional "gullwing" designs
- Series 399 is a matched pair of .050" pitch sockets and headers with a mated height of only .218"
- Series 340 is a .100" pitch SIP socket using a Hi-Rel, 4-finger BeCu #30 contact rated at 3 amps. See page 253 for details
- Insulators are high temperature thermoplastic, suitable for all soldering processes



ORDERING INFORMATION

FIG. 1	Series 399...310	Single Row .050" Grid Header			
		399-10-0	-00-310000		
	Specify number of pins		02-50		
	RoHS-2 2011/65/EU	XX=Plating Code See Below		For Electrical, Mechanical & Environmental Data, See page 264	
	SPECIFY PLATING CODE XX=	10			
	Pin Plating	10 μ" Au			
FIG. 2	Series 399...300	Single Row .050" Grid Socket			
		399-XX-0	-21-300000		
	Specify number of pins		02-50		
	RoHS-2 2011/65/EU	XX=Plating Code See Below		For Electrical, Mechanical & Environmental Data, See page 264	
	SPECIFY PLATING CODE XX=		91	41	
	Sleeve (Pin)	200 μ" Sn/Pb		200 μ" Sn	
	Contact (Clip)	10 μ" Au		10 μ" Au	
FIG. 3	Series 340...780	Single Row .100" Grid Socket			
		340-XX-1	-30-780100		
	Specify number of pins		02-64		
	RoHS-2 2011/65/EU	XX=Plating Code See Below		For Electrical, Mechanical & Environmental Data, See page 264	
	SPECIFY PLATING CODE XX=			99	44
	Sleeve (Pin)	200 μ" Sn/Pb		200 μ" Sn	
	Contact (Clip)	100 μ" Sn/Pb		100 μ" Sn	



INTERCONNECTS

SERIES 870 & 871 • .070" GRID (.018" DIA.) PINS, RIGHT ANGLE HEADERS & SOCKETS • SINGLE ROW STRIPS

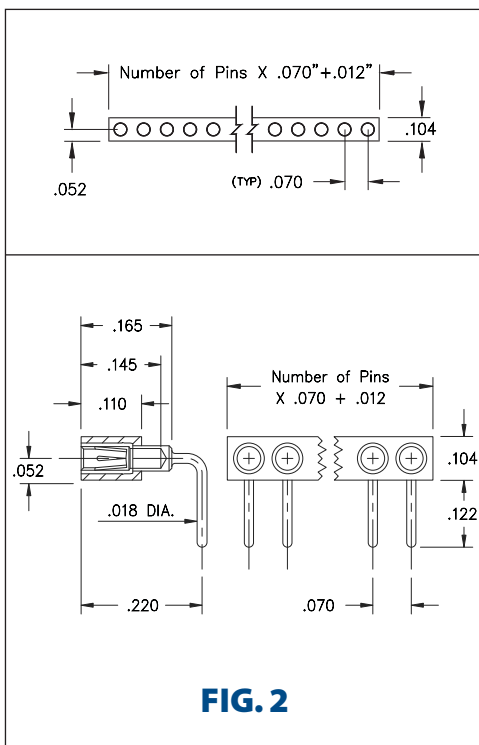
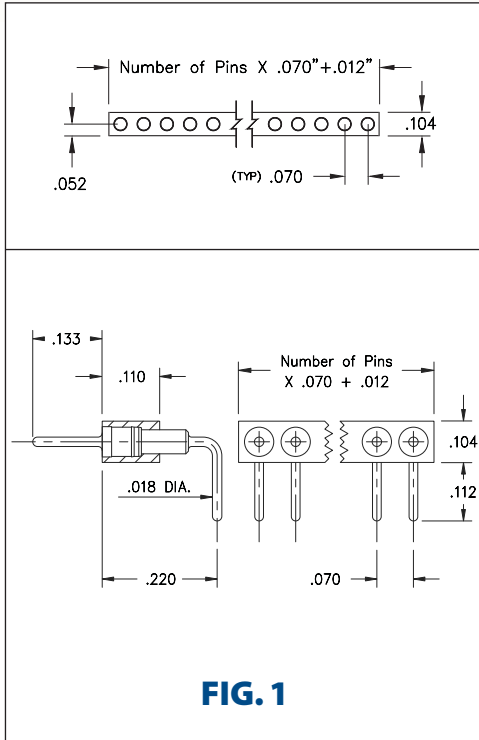

- Series 870 and 871 Interconnects feature space saving .070" pitch
- Series 870 uses MM #3790-0 pins. See page 209 for details
- Series 871 uses MM #1805 receptacles and accept pin diameters from .015" - .025". See page 169 for details
- Receptacles use Hi-Rel, 4-finger BeCu #30 contact rated at 3 amps. See page 253 for details
- Insulators are high temperature thermoplastic, suitable for all soldering operations

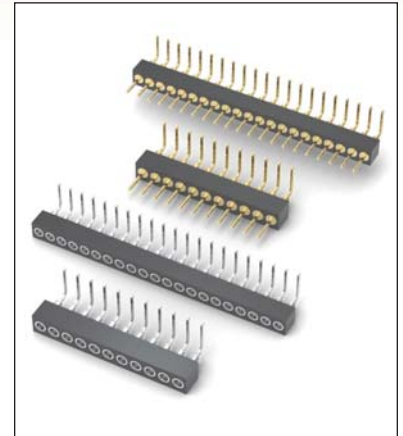

ORDERING INFORMATION

FIG. 1	Series 870...20-001	Right Angle Pin Header		
	870-10-0	-20-001000		
	Specify number of pins	10	02-21	
	RoHS - 2 2011/65/EU	XX=Plating Code See Below	For Electrical, Mechanical & Environmental Data, See page 264	
	SPECIFY PLATING CODE XX=	10		
	Pin Plating	10 μ" Au		

FIG. 2	Series 871...20-001	Right Angle Socket		
	871-XX-0	-20-001000		
	Specify number of pins	10	02-21	
	RoHS - 2 2011/65/EU	XX=Plating Code See Below	For Electrical, Mechanical & Environmental Data, See page 264	
	SPECIFY PLATING CODE XX=		41	43
	Sleeve (Pin)	200 μ" Sn	200 μ" Sn	
	Contact (Clip)	10 μ" Au	30 μ" Au	

INTERCONNECTS

SERIES 830, 831, 832, 833 • 2mm GRID HEADERS AND SOCKETS • SINGLE AND DOUBLE ROW STRIPS

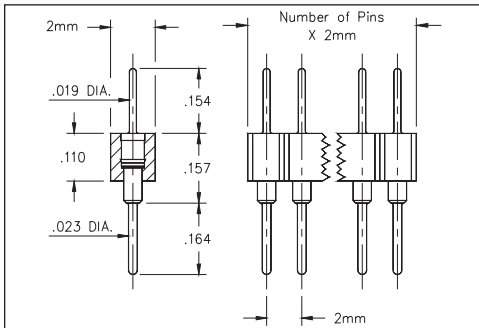

FIG. 1

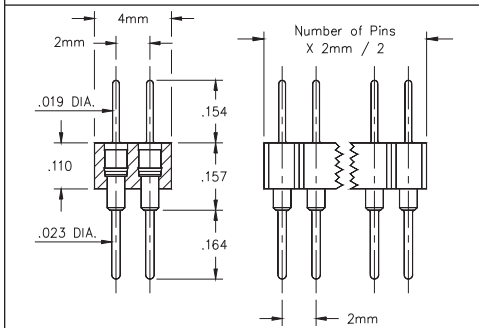

FIG. 2

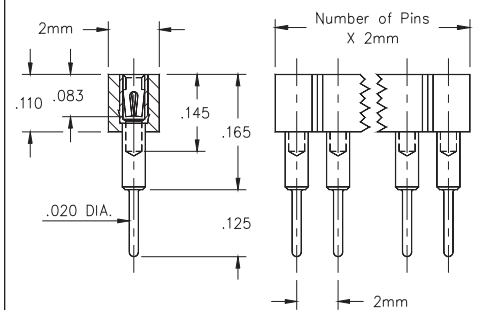

FIG. 3

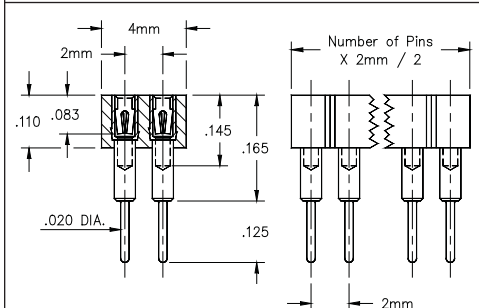

FIG. 4

- Series 830 single & double row interconnects have 2mm pin spacing and permit board stacking as low as .322"
- Pin headers (830 & 832 series) use MM #5012 pins. See page 208 for details
- Sockets (831 & 833 series) use MM #1802 receptacles and accept pin diameters from .015"-.025". See page 169 for details
- Contact is rated at 3 amps
- Insulators are high temperature thermoplastic, suitable for all soldering operations



ORDERING INFORMATION

FIG. 1	Series 830...001	Single Row Pin Header		
	830-XX-0	-10-001000	Specify number of pins 01-50	
FIG. 2	Series 832...001	Double Row Pin Header		
	832-XX-	-10-001000	Specify number of pins 002-100	
XX=Plating Code See Below For Electrical, Mechanical & Environmental Data, See page 264				
SPECIFY PLATING CODE XX=				
Pin Plating	10	90	40	
	10 μ " Au	200 μ " Sn/Pb	200 μ " Sn	

FIG. 3	Series 831...001	Single Row Socket			
	831-XX-0	-10-001000	Specify number of pins 01-50		
FIG. 4	Series 833...001	Double Row Socket			
	833-XX-	-10-001000	Specify number of pins 002-100		
XX=Plating Code See Below For Electrical, Mechanical & Environmental Data, See page 264					
SPECIFY PLATING CODE XX=					
Sleeve (Pin)		91	93	41	43
		200 μ " Sn/Pb	200 μ " Sn/Pb	200 μ " Sn	200 μ " Sn
Contact (Clip)		10 μ " Au	30 μ " Au	10 μ " Au	30 μ " Au



INTERCONNECTS

SERIES 830, 831, 832, 833 • 2mm GRID GULL WING SURFACE MOUNT HEADERS AND SOCKETS • SINGLE AND DOUBLE ROW STRIPS

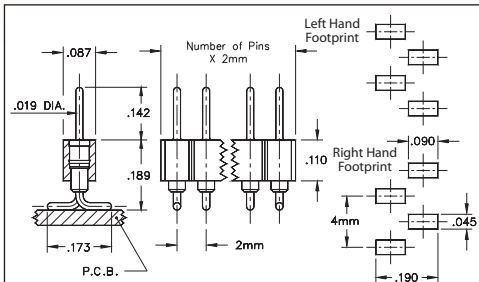

Coplanarity .005". For pin counts >12 positions, consult Technical Support.

FIG. 1

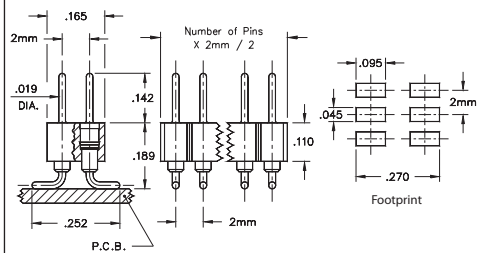

Coplanarity .005". For pin counts >24 positions, consult Technical Support.

FIG. 2

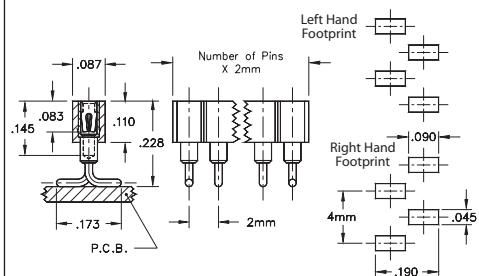

Coplanarity .005". For pin counts >12 positions, consult Technical Support.

FIG. 3

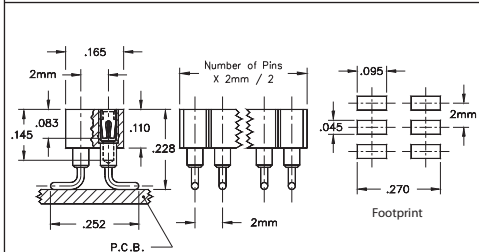

Coplanarity .005". For pin counts >24 positions, consult Technical Support.

FIG. 4

- Headers (830 & 832) use MM #6218 pins. See page 208 for details
- Sockets (831 & 833) use MM #1802 receptacles and accept pin diameters from .015"-.025". See page 169 for details
- Coplanarity .005" (Single Row max 12 pins; Double Row max 24 pins) For higher pin counts, contact Technical Support
- Contact is rated at 3 amps
- Insulators are high temperature thermoplastic, suitable for all soldering operations

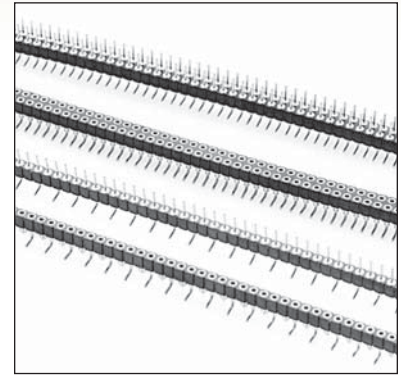

ORDERING INFORMATION

FIG. 1L	Single Row Header, Left Hand Footprint, Odd or Even # of pins				
	830-XX-0__-30-001000 Specify number of pins <input type="text" value="01-50"/>				
FIG. 1R	Single Row Header, Right Hand Footprint, Even # of pins				
	830-XX-0__-30-002000 Specify number of pins <input type="text" value="02-50"/>				
FIG. 2	Double Row Header, Even # of pins				
	832-XX-__-30-001000 Specify number of pins <input type="text" value="004-100"/>				
SPECIFY PLATING CODE XX=		10	90	40	
Pin Plating		10 μ" Au	200 μ" Sn/Pb	200 μ" Sn	
FIG. 3L	Single Row Socket, Left Hand Footprint, Odd or Even # of pins				
	831-XX-0__-30-001000 Specify number of pins <input type="text" value="01-50"/>				
FIG. 3R	Single Row Socket, Right Hand Footprint, Even # of pins				
	831-XX-0__-30-002000 Specify number of pins <input type="text" value="02-50"/>				
FIG. 4	Double Row Socket, Even # of pins				
	833-XX-__-30-001000 Specify number of pins <input type="text" value="004-100"/>				
		XX=Plating Code See Below		For Electrical, Mechanical & Environmental Data, See page 264	
SPECIFY PLATING CODE XX=		91	93	41	43
Sleeve (Pin)		200 μ" Sn/Pb	200 μ" Sn/Pb	200 μ" Sn	200 μ" Sn
Contact (Clip)		10 μ" Au	30 μ" Au	10 μ" Au	30 μ" Au

INTERCONNECTS

SERIES 830, 831, 832, 833 • 2mm GRID RIGHT ANGLE HEADERS AND SOCKETS • SINGLE AND DOUBLE ROW STRIPS

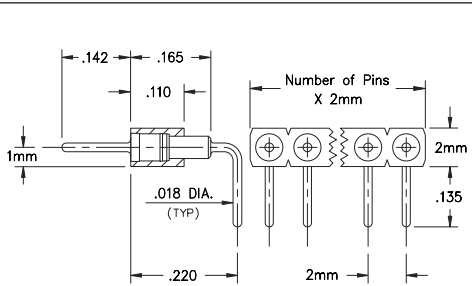

FIG. 1

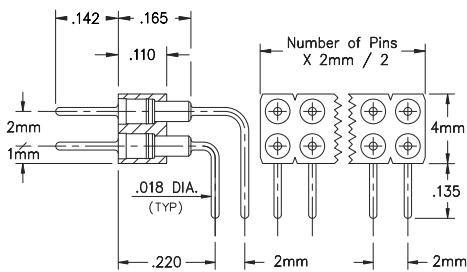

FIG. 2

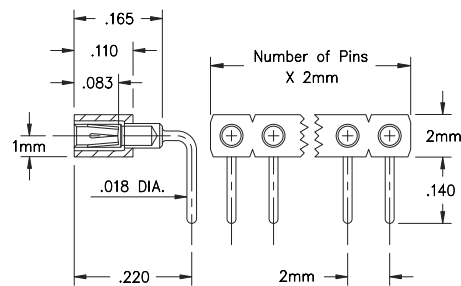

FIG. 3

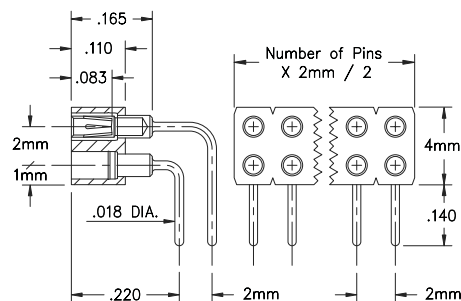
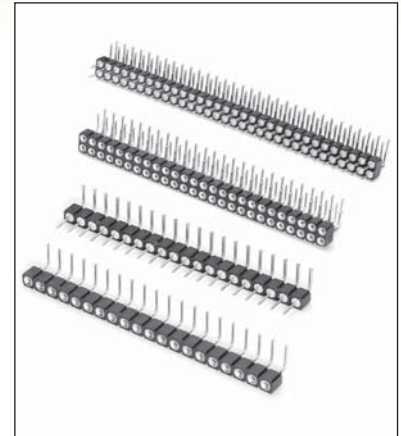

FIG. 4

- Series 830 & 832 use MM #3790 & MM #3796 pins. See page 209 for details
- Series 831 & 833 use MM #1805 and MM #3805 receptacles and accept pin diameters from .015"-.025". See page 169 for details
- Receptacles use Hi-Rel, Low force, 6-finger BeCu #32 contact rated at 3 amps. See page 253 for details
- Insulators are high temperature thermoplastic, suitable for all soldering operations



ORDERING INFORMATION

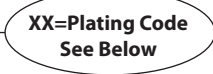



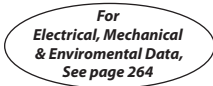

FIG. 1	Series 830...001	Single Row Right Angle Header				
	830-10-0	-20-001000	Specify number of pins	01-50		
FIG. 2	Series 832...001	Double Row Right Angle Header				
	832-10-	-20-001000	Specify number of pins	002-100		
  						
SPECIFY PLATING CODE XX=		10				
Pin Plating			10 μ" Au			

FIG. 3	Series 831...001	Single Row Right Angle Socket				
	831-XX-0	-20-001000	Specify number of pins	01-50		
FIG. 4	Series 833...001	Double Row Right Angle Socket				
	833-43-	-20-001000	Specify number of pins	002-100		
  						
SPECIFY PLATING CODE XX=				41	43	
Sleeve (Pin)				200 μ" Sn	200 μ" Sn	
Contact (Clip)				10 μ" Au	30 μ" Au	



INTERCONNECTS

SERIES 301, 310, 350, 399 • .100" GRID (.018" DIA.) PINS, STRAIGHT AND RIGHT ANGLE • SINGLE ROW STRIPS

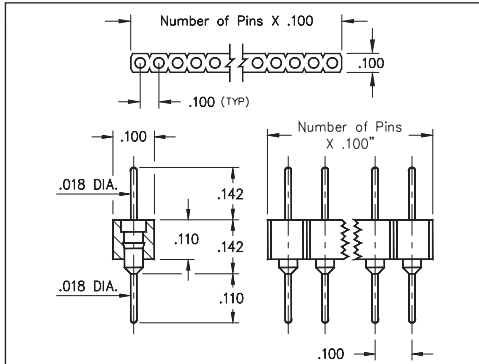

FIG. 1

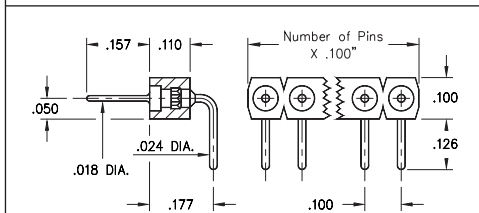

FIG. 2

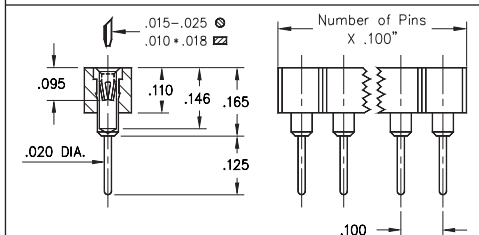

FIG. 3

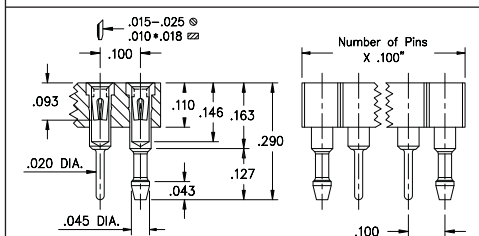

FIG. 4

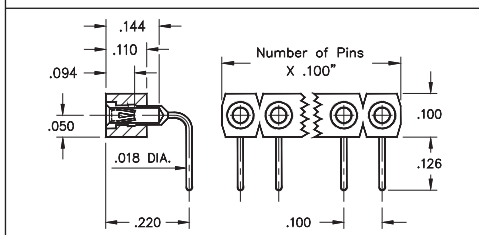

FIG. 5

- Series 3XX are available with straight and right angle solder tails
- Series 350 & 399...009 use MM #3404 and #5011 pins. See pages 212 & 214 for details
- Series 301, 310 & 399...003 use MM #0156, #1001 & #1103 receptacles. See pages 165 and 166 for details
- Receptacles use Hi-Rel, 4-finger #30 BeCu contact rated at 3 amps. See page 253 for details
- Insulators are high temperature thermoplastic, suitable for all soldering operations



ORDERING INFORMATION

FIG. 1	Series 350...006	Straight Pin Header			
	350-XX-1__-00-006000	Specify number of pins \uparrow 01-64			
FIG. 2	Series 399...009	Right Angle Pin Header			
	399-XX-1__-10-009000	Specify number of pins \uparrow 02-64			
SPECIFY PLATING CODE XX=		10	90	40	
Pin Plating		10 μ " Au	200 μ " Sn/Pb	200 μ " Sn	
FIG. 3	Series 310...001	Solder Tail Socket			
	310-XX-1__-41-001000	Specify number of pins \uparrow 01-64			
FIG. 4	Series 301...056	Socket with Retention Pins			
	301-43-1__-41-560000	Specify number of pins \uparrow 03-64			
FIG. 5	Series 399...003	Right Angle Socket			
	399-XX-1__-10-003000	Specify number of pins \uparrow 02-64			
SPECIFY PLATING CODE XX=		11	13	91	93
Sleeve (Pin)		10 μ " Au	10 μ " Au	200 μ " Sn/Pb	200 μ " Sn/Pb
Contact (Clip)		10 μ " Au	30 μ " Au	10 μ " Au	30 μ " Au
		200 μ " Sn	200 μ " Sn	100 μ " Sn/Pb	100 μ " Sn/Pb
		200 μ " Sn	200 μ " Sn	10 μ " Au	30 μ " Au
		200 μ " Sn	200 μ " Sn	100 μ " Sn	100 μ " Sn

★ 41, 91 & 99 Platings Non-Standard



INTERCONNECTS

SERIES 410, 450, 499 • .100" GRID (.018" DIA.) PINS, STRAIGHT AND RIGHT ANGLE • DOUBLE ROW STRIPS

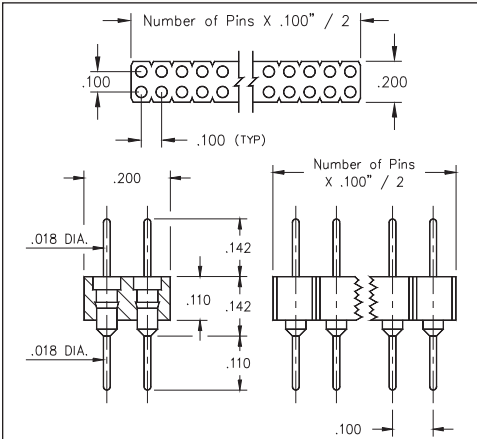

FIG. 1

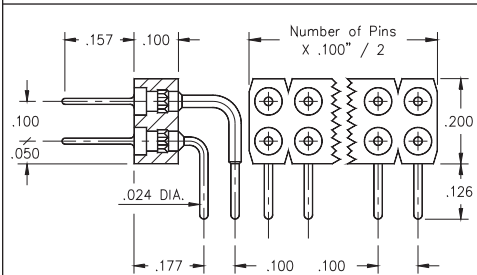

FIG. 2

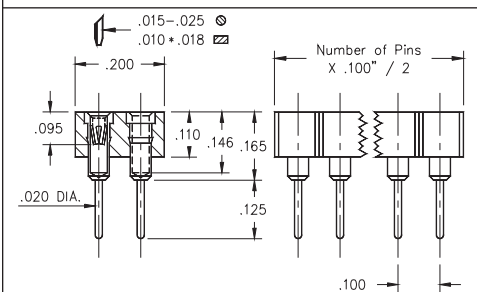

FIG. 3

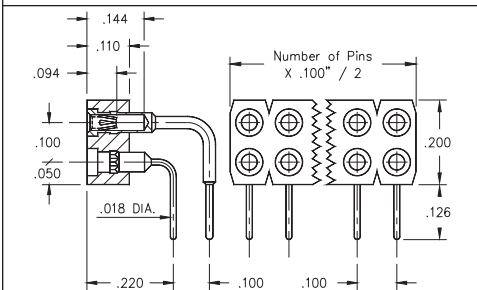
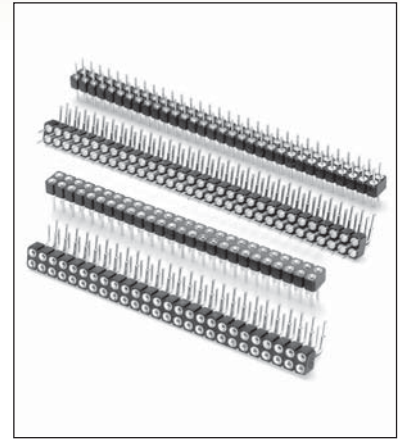

FIG. 4

- Series 4XX are available with straight and right angle solder tails
- Series 450 & 499...009 use MM #3404 and #5011/5113 pins. See pages 212 and 214 for details
- Series 410 & 499...003 use MM #1001 and #1103/1602 receptacles. See pages 165, 166 and 167 for details
- Receptacles use Hi-Rel, 4-finger #30 BeCu contact rated at 3 amps. See page 253 for details
- Insulators are high temperature thermoplastic, suitable for all soldering operations



ORDERING INFORMATION

FIG. 1	Series 450...006	Straight Pin Header		
	450-XX-2	-00-006000		
	Specify number of pins	02-64		
FIG. 2	Series 499...009	Right Angle Pin Header		
	499-10-2	-10-009000		
	Specify number of pins	02-64		
<div style="display: flex; justify-content: space-around; align-items: center;"> <div style="border: 1px solid black; padding: 5px; background-color: #90EE90;">RoHS-2 2011/65/EU</div> <div style="border: 1px solid black; border-radius: 50%; padding: 5px;">XX=Plating Code See Below</div> <div style="border: 1px solid black; border-radius: 50%; padding: 5px;">For Electrical, Mechanical & Environmental Data, See page 264</div> </div>				
SPECIFY PLATING CODE XX=				
Pin Plating	10 ◆	90	40 ◆	
	10 μ" Au	200 μ" Sn/Pb	200 μ" Sn	

FIG. 3	Series 410...001	Solder Tail Socket					
	410-XX-2	-41-001000					
	Specify number of pins	02-64					
FIG. 4	Series 499...003	Right Angle Socket					
	499-XX-2	-10-003000					
	Specify number of pins	02-64					
<div style="display: flex; justify-content: space-around; align-items: center;"> <div style="border: 1px solid black; padding: 5px; background-color: #90EE90;">RoHS-2 2011/65/EU</div> <div style="border: 1px solid black; border-radius: 50%; padding: 5px;">XX=Plating Code See Below</div> <div style="border: 1px solid black; border-radius: 50%; padding: 5px;">For Electrical, Mechanical & Environmental Data, See page 264</div> </div>							
SPECIFY PLATING CODE XX=							
Sleeve (Pin)		10 ◆	13 ◆	91	93	41 ◆	43 ◆
		10 μ" Au	10 μ" Au	200 μ" Sn/Pb	200 μ" Sn/Pb	200 μ" Sn	200 μ" Sn
Contact (Clip)		10 ◆	30 ◆	10 ◆	30 ◆	10 ◆	30 ◆
		10 μ" Au	30 μ" Au	10 μ" Au	30 μ" Au	10 μ" Au	30 μ" Au



INTERCONNECTS

SERIES 329, 380, 429, 480 • .100" GRID SOLDER CUP HEADERS AND SOCKETS • SINGLE AND DOUBLE ROW STRIPS

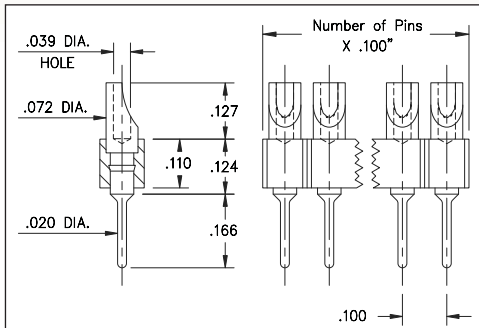

FIG. 1

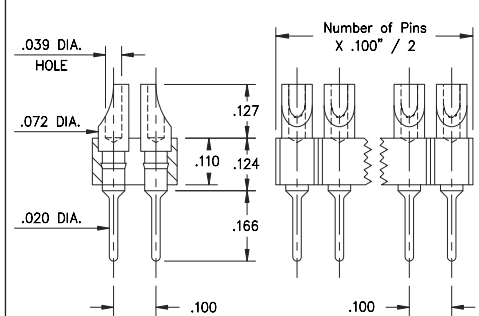

FIG. 2

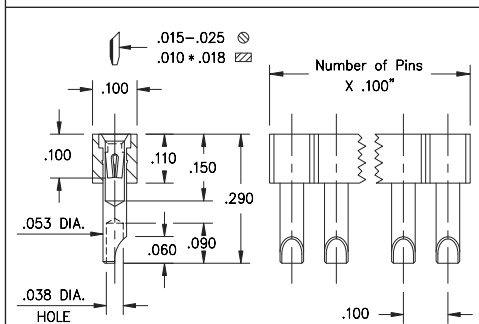

FIG. 3

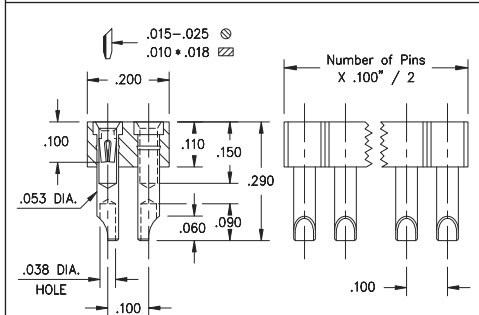
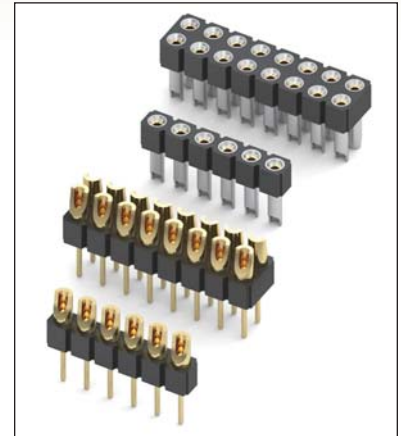

FIG. 4

- Series 380 & 480 use MM #8000 pins. See page 216 for details
- Series 329 & 429 use MM #2954 receptacles and accept pin diameters from .015"-.025". See page 171 for details
- Series 329 & 429 receptacles use Hi-Rel, 4-finger BeCu #30 contact rated at 3 amps. See page 253 for details
- Soldercups are pre-aligned
- Insulators are high temperature thermoplastic, suitable for all soldering operations



ORDERING INFORMATION

FIG. 1	Series 380...001	Single Row Solder Cup / Solder Tail		
	380-XX-1	-00-001000	Specify number of pins 01-64	
FIG. 2	Series 480...001	Double Row Solder Cup / Solder Tail		
	480-10-2	-00-001000	Specify number of pins 02-64	
XX=Plating Code See Below For Electrical, Mechanical & Environmental Data, See page 264				
SPECIFY PLATING CODE XX=		10	90	40
Pin Plating		10 μ" Au	200 μ" Sn/Pb	200 μ" Sn

FIG. 3	Series 329...540	Single Row Solder Cup Sockets			
	329-XX-1	-41-540000	Specify number of pins 01-64		
FIG. 4	Series 429...540	Double Row Solder Cup Sockets			
	429-XX-2	-41-540000	Specify number of pins 02-64		
XX=Plating Code See Below For Electrical, Mechanical & Environmental Data, See page 264					
SPECIFY PLATING CODE XX=		11	13	41	43
Sleeve (Pin)		10 μ" Au	10 μ" Au	200 μ" Sn	200 μ" Sn
Contact (Clip)		10 μ" Au	30 μ" Au	10 μ" Au	30 μ" Au



INTERCONNECTS

SERIES 329, 340, 414, 429 • .100" GRID SURFACE MOUNT HEADERS AND SOCKETS • SINGLE AND DOUBLE ROW STRIPS

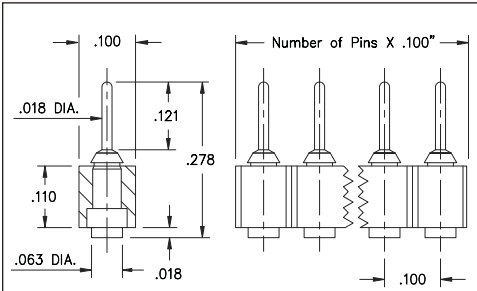

FIG. 1

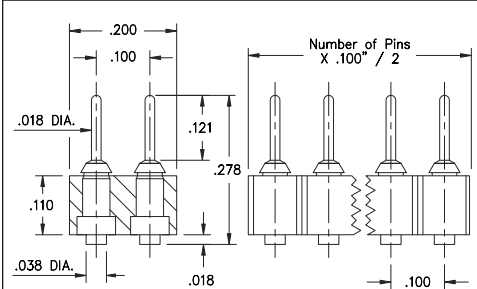

FIG. 2

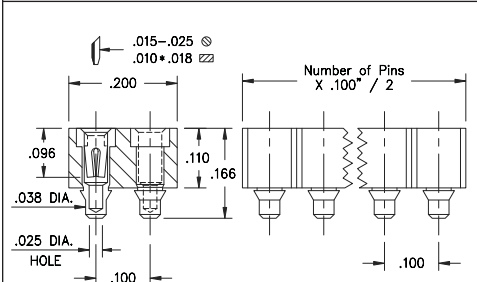

FIG. 3

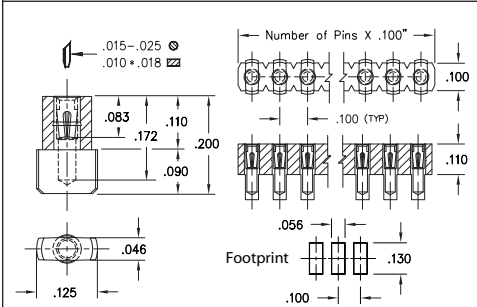
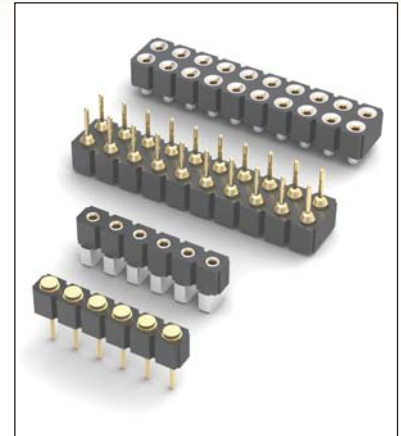

FIG. 4

Coplanarity .005". For pin counts >10 positions, consult Technical Support.

- Series 329 and 429 pin interconnects feature space saving, pad style SMT termination using MM #2956-X pins. See page 218 for details
- Series 429 and 414 combine for a mated height of .323"
- Series 340 and 414 surface mount sockets use MM #4078 and #1434 receptacles. See pages 162 and 167 for details
- Series 340 and 414 receptacles use Hi-Rel, 4-finger BeCu #30 contacts rated at 3 amps. Receptacles accept .015"-.025" diameter pins See page 253 for details
- Insulators are high temperature thermoplastic, suitable for all soldering operations



ORDERING INFORMATION







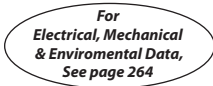

FIG. 1	Series 329...560	Single Row Surface Mount Pin Header				
			329-10-1	-00-560000		
		Specify number of pins		02-64		
FIG. 2	Series 429...560	Double Row Surface Mount Pin Header				
			429-10-2	-00-560000		
		Specify number of pins		04-72		
						
SPECIFY PLATING CODE XX=			10			
Pin Plating 			10 μ" Au			

FIG. 3	Series 414...117	Double Row Surface Mount Socket				
			414-XX-2	-41-117000		
		Specify number of pins		04-72		
FIG. 4	Series 340...780	Single Row Surface Mount Socket				
			340-XX-1	-30-780100		
		Specify number of pins		02-64		
						
SPECIFY PLATING CODE XX=				99	41	43
Sleeve (Pin) 				200 μ" Sn/Pb	200 μ" Sn	200 μ" Sn
Contact (Clip) 				100 μ" Sn/Pb	10 μ" Au	30 μ" Au
					44	100 μ" Sn



INTERCONNECTS

SERIES 310, 351, 800, 801 • .100" GRID HORIZONTAL SURFACE MOUNT HEADERS AND Z-BEND SOCKETS • SINGLE ROW STRIPS

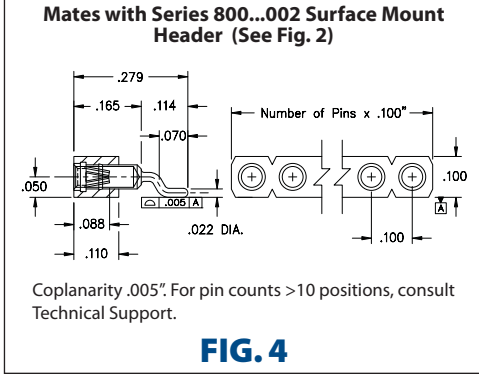
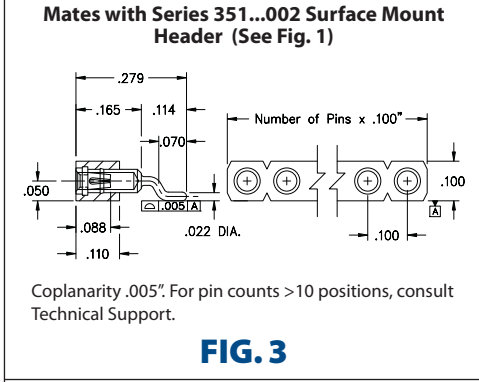
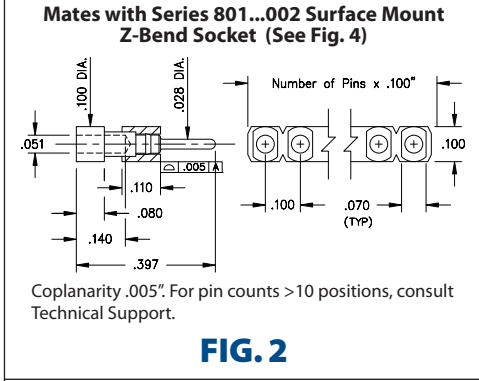
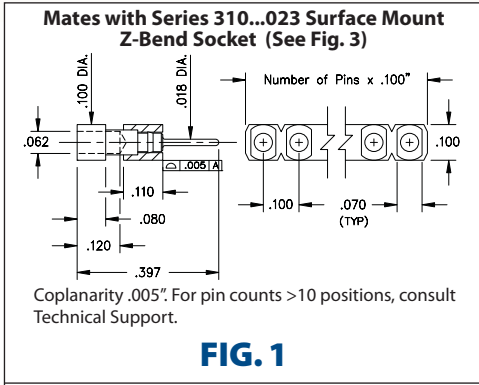

- Series 351 and 800 horizontal surface mount headers are available with .018" dia. pluggable pins (MM #5102) and .028" dia. pluggable pins (MM #1502). See page 224 for details
- Series 310 horizontal surface mount Z-Bend sockets uses MM #1023 receptacles that accept pin diameters from .015"-.025". Series 801 use MM #1303 receptacles that accept pin diameters from .025"-.037" and .025" square leads. See pages 171 and 180 for details
- Insulators are high temperature thermoplastic, suitable for all soldering operations
- Ideal for daisy chaining parallel boards

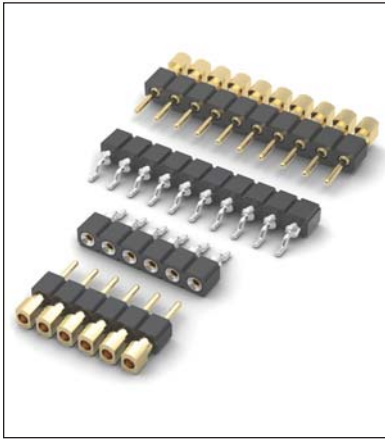

ORDERING INFORMATION







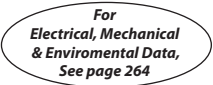



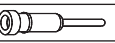

FIG. 1	Series 351...002 .018" Dia. Surface Mount Header	351-10-1__-40-002000
	Specify number of pins	02-10
FIG. 2	Series 800...002 .028" Dia. Surface Mount Header	800-10-0__-40-002000
	Specify number of pins	02-10
  		
SPECIFY PLATING CODE XX=		10 
Pin Plating 		10 μ" Au

FIG. 3	Series 310...023 .018" Dia. Surface Mount Z-Bend Socket	310-XX-1__-40-023000
	Specify number of pins	02-10
FIG. 4	Series 801...002 .028" Dia. Surface Mount Z-Bend Socket	801-XX-0__-40-002000
	Specify number of pins	02-10
  		
SPECIFY PLATING CODE XX=		91 93 99 41  43  44 
Sleeve (Pin) 		200 μ" Sn/Pb 200 μ" Sn/Pb 200 μ" Sn/Pb 200 μ" Sn 200 μ" Sn 200 μ" Sn
Contact (Clip) 		10 μ" Au 30 μ" Au 100 μ" Sn/Pb 10 μ" Au 30 μ" Au 100 μ" Sn



INTERCONNECTS

SERIES 310, 350, 410, 450 • .100" GRID (.018" DIA. PINS), SMT GULL WING HEADERS & SOCKETS • SINGLE AND DOUBLE ROW STRIPS

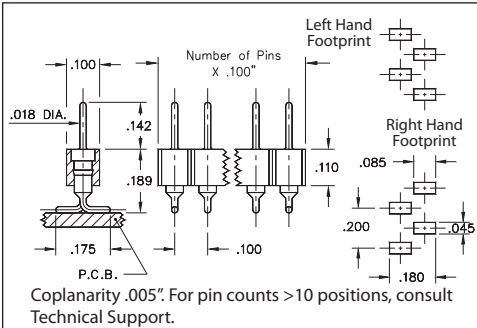

FIG. 1

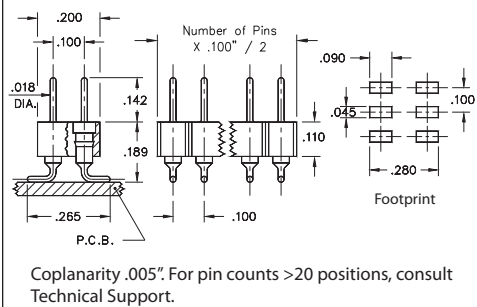

FIG. 2

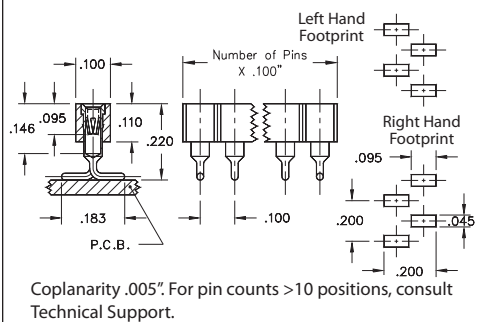

FIG. 3

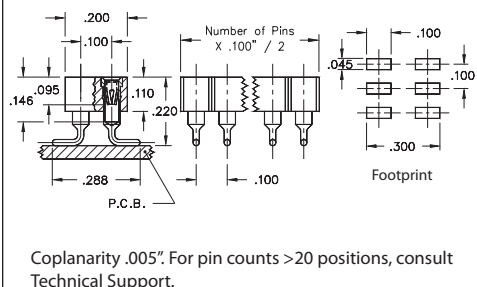
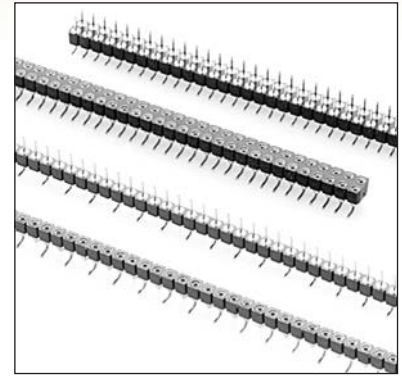

FIG. 4

- Headers (350 & 450) use MM #3404 pins. See page 212 for details
- Sockets (310 & 410) use MM #1005 receptacles and accept pin diameters from .015"-.025". See page 166 for details
- Contact is rated at 3 amps
- Coplanarity .005" (single row max. 10 pins; double row max. 20 pins). For higher pin counts, contact Technical Support
- Insulators are high temperature thermoplastic, suitable for all soldering operations



ORDERING INFORMATION

FIG. 1L	Single Row Header, Left Hand Footprint, Odd or Even # of pins				
	350-XX-1__-00-106000 Specify number of pins 02-64				
FIG. 1R	Single Row Header, Right Hand Footprint, Even # of pins				
	350-XX-1__-00-107000 Specify number of pins 02-64				
FIG. 2	Double Row Header, Even # of pins				
	450-XX-2__-00-106000 Specify number of pins 04-72				
SPECIFY PLATING CODE XX=		10 ◆	90	40 ◆	
Pin Plating		10 μ" Au	200 μ" Sn/Pb	200 μ" Sn	
FIG. 3L	Single Row Socket, Left Hand Footprint, Odd or Even # of pins				
	310-XX-1__-41-105000 Specify number of pins 02-64				
FIG. 3R	Single Row Socket, Right Hand Footprint, Even # of pins				
	310-XX-1__-41-107000 Specify number of pins 02-64				
FIG. 4	Double Row Socket, Even # of pins				
	410-XX-2__-41-105000 Specify number of pins 04-72				
		XX=Plating Code See Below		For Electrical, Mechanical & Environmental Data, See page 264	
SPECIFY PLATING CODE XX=		91	93	41 ◆	43 ◆
Sleeve (Pin)		200 μ" Sn/Pb	200 μ" Sn/Pb	200 μ" Sn	200 μ" Sn
Contact (Clip)		10 μ" Au	30 μ" Au	10 μ" Au	30 μ" Au



INTERCONNECTS

SERIES 350, 450, 801, 803 • .100" GRID (.025" DIA. PINS), LOW PROFILE HEADERS & VERSATILE SOCKETS • SINGLE & DOUBLE ROW STRIPS

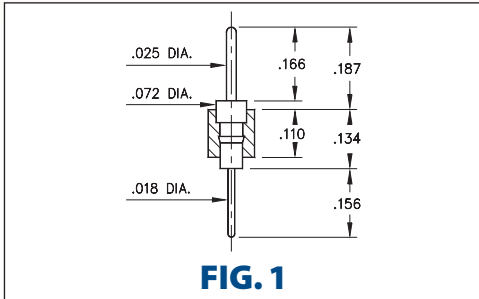

FIG. 1

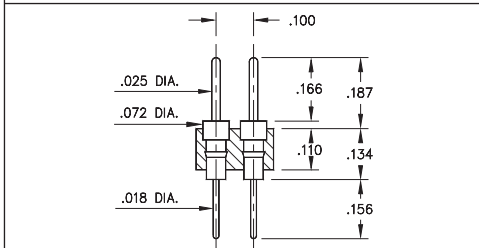

FIG. 2

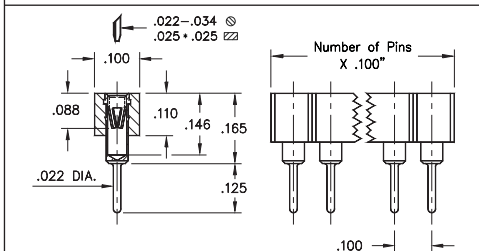

FIG. 3

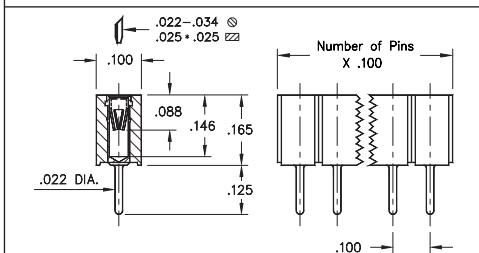

FIG. 4

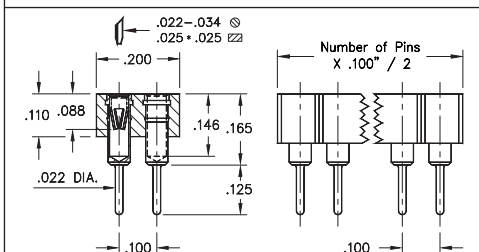

FIG. 5

- Series 350 and 450 single and double row pin headers use MM #0290 pins. See page 215 for details
- Series 801 and 803 single and double row low profile sockets use MM #1303 receptacles. See page 180 for details
- Series 801 and 803 receptacles use Hi-Rel, 6-finger BeCu #16 contact rated at 4.5 amps. Receptacles accept .025" diameter and .025" square pins. See page 256 for details
- Insulators are high temperature thermoplastic, suitable for all soldering operations



ORDERING INFORMATION

FIG. 1	Series 350...001 Single Row .025" Pin / .018" Solder Tail	350-XX-1__-00-001000			
	Specify number of pins	↑ 01-64			
FIG. 2	Series 450...001 Double Row .025" Pin / .018" Solder Tail	450-XX-2__-00-001000			
	Specify number of pins	↑ 02-64			
SPECIFY PLATING CODE XX=		10	90	40	
Pin Plating		10 μ" Au	200 μ" Sn/Pb	200 μ" Sn	
FIG. 3	Series 801...003 Low Profile Socket (short insulator)	801-XX-0__-10-003000			
	Specify number of pins	↑ 01-64			
FIG. 4	Series 801...013 Low Profile Socket (long insulator)	801-XX-0__-10-013000			
	Specify number of pins	↑ 01-36			
FIG. 5	Series 803...003 Double Row Low Profile Socket	803-XX-0__-10-003000			
	Specify number of pins	↑ 02-72			
SPECIFY PLATING CODE XX=				41	43
Sleeve (Pin)				200 μ" Sn	200 μ" Sn
Contact (Clip)				10 μ" Au	30 μ" Au



INTERCONNECTS

SERIES 800, 801, 802, 803 • .100" GRID (.030" DIA. PINS), LOW PROFILE HEADERS & VERSATILE SOCKETS • SINGLE & DOUBLE ROW STRIPS

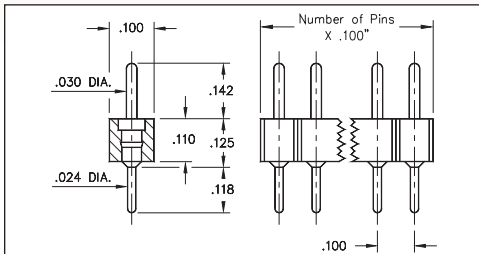

FIG. 1

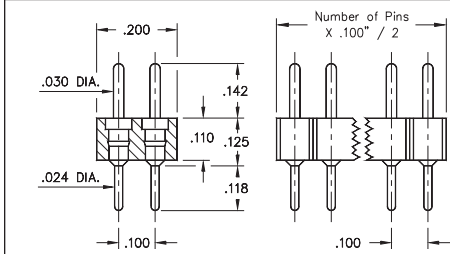

FIG. 2

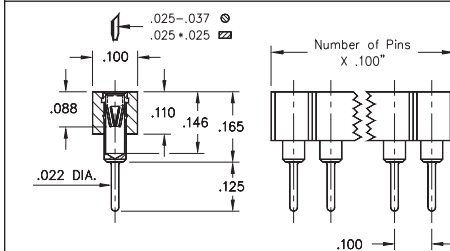

FIG. 3

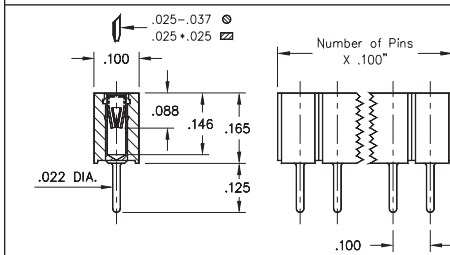

FIG. 4

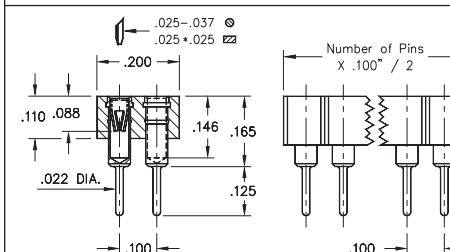

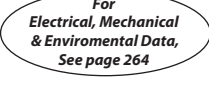





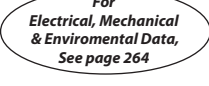





FIG. 5

- Series 800 and 802 single and double row pin headers use MM #5016 pins. See page 215 for details
- Series 801 and 803 single and double row sockets use MM #1303 receptacles. See page 180 for details
- Series 801 and 803 receptacles use Hi-Rel, 6-finger BeCu #47 contact rated at 4.5 amps. Receptacles accept .030" diameter and .025" square pins. See page 256 for details
- Insulators are high temperature thermoplastic, suitable for all soldering operations



ORDERING INFORMATION

FIG. 1	Series 800...002	Single Row Low Profile Pin Header				
	800-XX-0	-10-002000	Specify number of pins \uparrow 01-64			
FIG. 2	Series 802...002	Double Row Low Profile Pin Header				
	802-XX-0	-10-002000	Specify number of pins \uparrow 04-64			
						
SPECIFY PLATING CODE XX=		10 	90	40 		
Pin Plating 		10 μ " Au	200 μ " Sn/Pb	200 μ " Sn		
FIG. 3	Series 801...002	Low Profile Socket (short insulator)				
	801-XX-0	-10-002000	Specify number of pins \uparrow 01-64			
FIG. 4	Series 801...012	Low Profile Socket (long insulator)				
	801-XX-0	-10-012000	Specify number of pins \uparrow 01-36			
FIG. 5	Series 803...002	Double Row Low Profile Socket				
	803-XX-0	-10-002000	Specify number of pins \uparrow 04-72			
						
SPECIFY PLATING CODE XX=		91	93	99	41 	43 
Sleeve (Pin) 		200 μ " Sn/Pb	200 μ " Sn/Pb	200 μ " Sn/Pb	200 μ " Sn	200 μ " Sn
Contact (Clip) 		10 μ " Au	30 μ " Au	100 μ " Sn/Pb	10 μ " Au	30 μ " Au

INTERCONNECTS

SERIES 800 & 801 • .100" GRID (.030" DIA. PINS), STRAIGHT & RIGHT ANGLE HEADERS AND SOCKETS • SINGLE ROW STRIPS

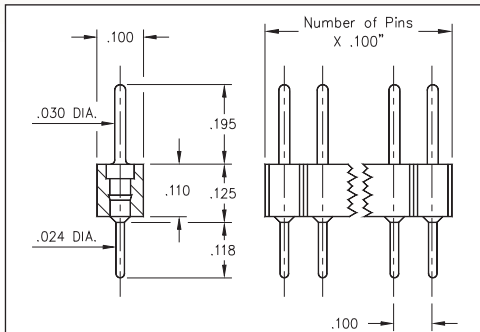

FIG. 1

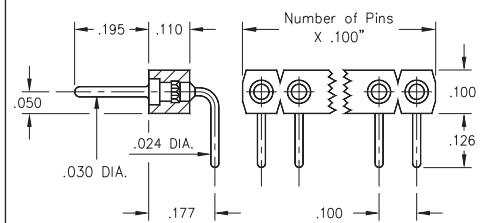

FIG. 2

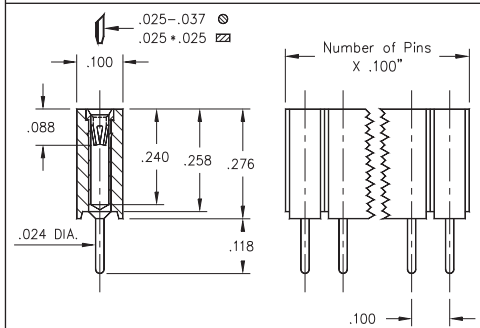

FIG. 3

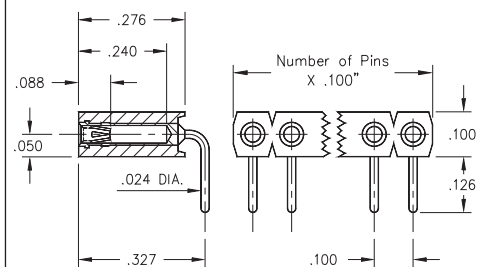
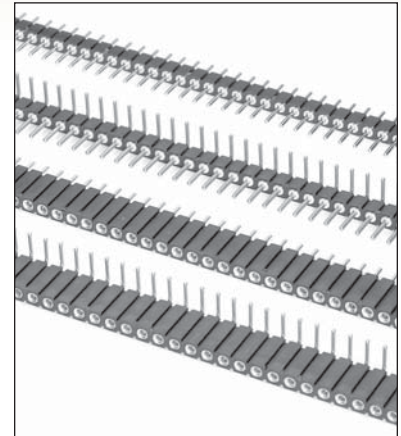

FIG. 4

- Pin interconnects available with straight MM #7007 or right angle MM #5005 solder tails. See page 215 for details
- Sockets are available with straight MM #1304 or right angle MM #1305 soldertails. See pages 177 and 179 for details
- MM #1304 and MM #1305 receptacles use Hi-Rel, 6-finger BeCu #47 contact rated at 4.5 amps. Receptacles accept .030" diameter and .025" square pins. See page 256 for details
- Insulators are high temperature thermoplastic, suitable for all soldering operations



ORDERING INFORMATION







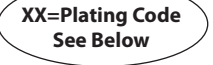
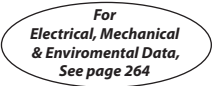



FIG. 1	Series 800...10-001		Straight Pin Header	
		800-XX-0	-10-001000	01-64
	Specify number of pins			
FIG. 2	Series 800...20-001		Right Angle Pin Header	
		800-XX-0	-20-001000	02-64
	Specify number of pins			
  				
SPECIFY PLATING CODE XX=				
Pin Plating 				
	10 	90	40 	
	10 μ" Au	200 μ" Sn/Pb	200 μ" Sn	

FIG. 3	Series 801...10-001		Straight Socket			
		801-XX-0	-10-001000	01-50		
	Specify number of pins					
FIG. 4	Series 801...20-001		Right Angle Socket			
		801-XX-0	-20-001000	01-50		
	Specify number of pins					
  						
SPECIFY PLATING CODE XX=						
Sleeve (Pin) 						
Contact (Clip) 						
		91	93	99	41 	43 
		200 μ" Sn/Pb	200 μ" Sn/Pb	200 μ" Sn/Pb	200 μ" Sn	200 μ" Sn
		10 μ" Au	30 μ" Au	100 μ" Sn/Pb	10 μ" Au	30 μ" Au
					100 μ" Sn	100 μ" Sn

★ 44 Plating Non-Standard



INTERCONNECTS

SERIES 802 & 803 • .100" GRID (.030" DIA. PINS), STRAIGHT & RIGHT ANGLE HEADERS AND SOCKETS • DOUBLE ROW STRIPS

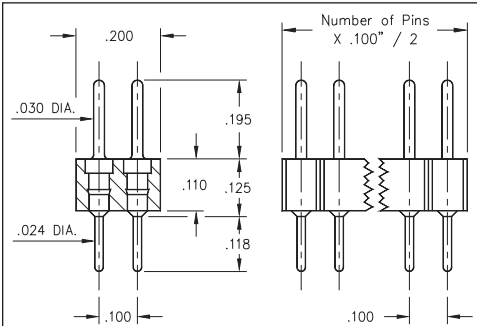

FIG. 1

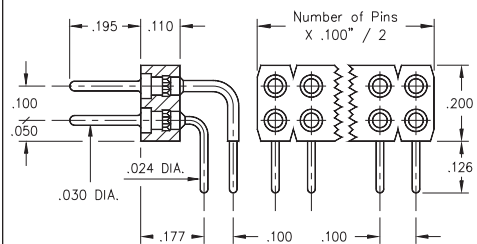

FIG. 2

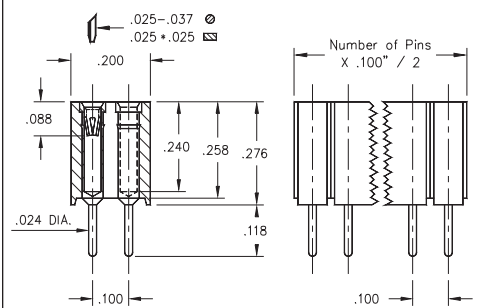

FIG. 3

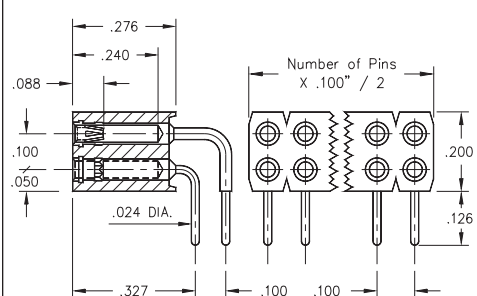
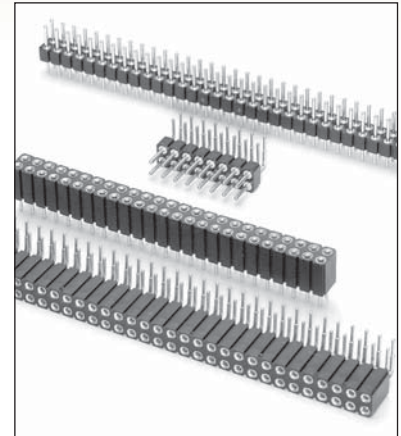

FIG. 4

- Pin interconnects available with straight MM #7007 or right angle MM #5005/5107 solder tails. See page 215 for details
- Sockets are available with straight MM #1304 or right angle MM #1305/1306 soldertails. See pages 177 and 179 for details
- MM #1304, #1305 and #1306 receptacles use Hi-Rel, 6-finger BeCu #47 contact rated at 4.5 amps. Receptacles accept .030" diameter and .025" square pins. See page 256 for details
- Insulators are high temperature thermoplastic, suitable for all soldering operations



ORDERING INFORMATION

FIG. 1	Series 802...10-001	Straight Pin Header		
	802-XX-0-10-001000	Specify number of pins: 04-64		
FIG. 2	Series 802...20-001	Right Angle Pin Header		
	802-XX-0-20-001000	Specify number of pins: 02-64		
XX=Plating Code See Below For Electrical, Mechanical & Environmental Data, See page 264				
SPECIFY PLATING CODE XX=				
Pin Plating				
	10	90	40	
	10 μ" Au	200 μ" Sn/Pb	200 μ" Sn	

FIG. 3	Series 803...10-001	Straight Socket				
	803-XX-10-001000	Specify number of pins: 004-100				
FIG. 4	Series 803...20-001	Right Angle Socket				
	803-XX-20-001000	Specify number of pins: 002-100				
XX=Plating Code See Below For Electrical, Mechanical & Environmental Data, See page 264						
SPECIFY PLATING CODE XX=						
Sleeve (Pin)						
Contact (Clip)						
	91	93	99	41	43	
	200 μ" Sn/Pb	200 μ" Sn/Pb	200 μ" Sn/Pb	200 μ" Sn	200 μ" Sn	
	10 μ" Au	30 μ" Au	100 μ" Sn/Pb	10 μ" Au	30 μ" Au	



INTERCONNECTS

SERIES 800 & 801 • .100" GRID (.030" DIA. PINS), SOLDERLESS PRESS-FIT • SINGLE ROW STRIPS

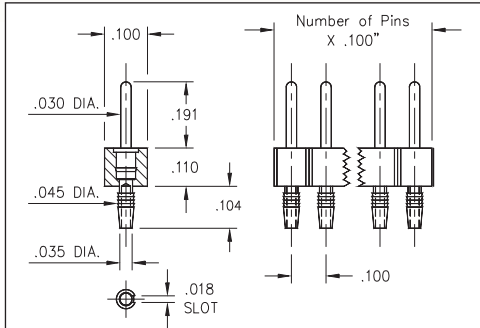

FIG. 1

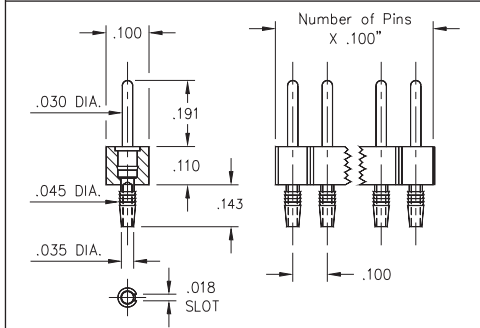

FIG. 2

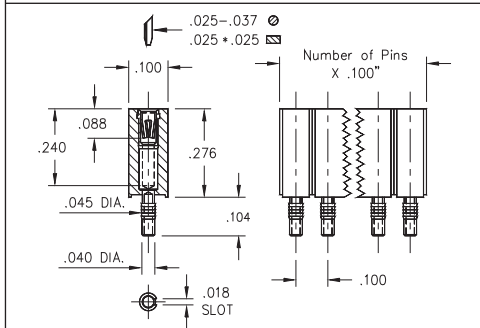

FIG. 3

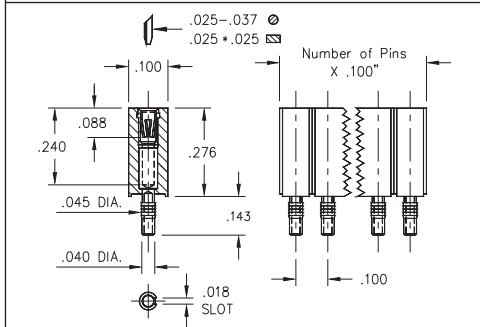
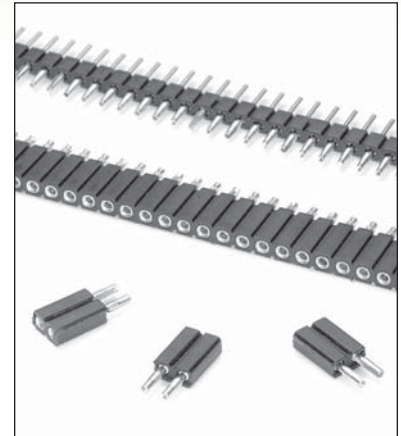

FIG. 4

- The unique compliant tail pins conform to .040"±.003" finished hole without stressing inner layers. Patent No. 4,799,904
- Headers and sockets are available for board thicknesses of .060" - .100" and .090" - .130". See ordering information for details
- Series 800 pin headers use MM #5601 and #5602 compliant tail pins featuring a .030" dia. mating lead. See page 220 for details
- Series 801 sockets MM #4614 or #4615 use Hi-Rel, 6-finger BeCu #47 contact rated at 4.5 amps. Receptacles accept .030" diameter pins & .025" square pins. See pg. 256 for details
- Insulators are high temperature thermoplastic



ORDERING INFORMATION

FIG. 1	Compliant Tail Pin Header for .060" - .100" Thick Boards				
	800-XX-0__-61-001000 Specify number of pins 01-64				
FIG. 2	Compliant Tail Pin Header for .090" - .130" Thick Boards				
	800-XX-0__-62-001000 Specify number of pins 01-64				
SPECIFY PLATING CODE XX=		10	90	40	
Pin Plating		10 μ" Au	200 μ" Sn/Pb	200 μ" Sn	

FIG. 3	Compliant Tail Socket for .060" - .100" Thick Boards						
	801-XX-0__-61-001000 Specify number of pins 01-50						
FIG. 4	Compliant Tail Socket for .090" - .130" Thick Boards						
	801-XX-0__-62-001000 Specify number of pins 01-50						
SPECIFY PLATING CODE XX=			91	93	99	41	43
Sleeve (Pin)			200 μ" Sn/Pb	200 μ" Sn/Pb	200 μ" Sn/Pb	200 μ" Sn	200 μ" Sn
Contact (Clip)			10 μ" Au	30 μ" Au	100 μ" Sn/Pb	10 μ" Au	30 μ" Au



INTERCONNECTS

SERIES 802 & 803 • .100" GRID (.030" DIA. PINS), SOLDERLESS PRESS-FIT • DOUBLE ROW STRIPS

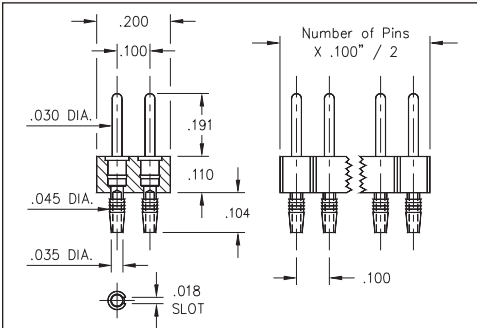

FIG. 1

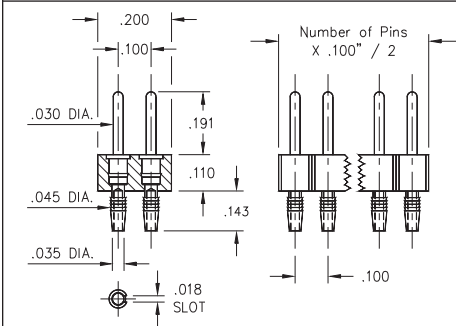

FIG. 2

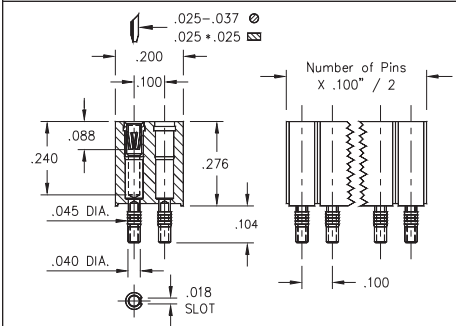

FIG. 3

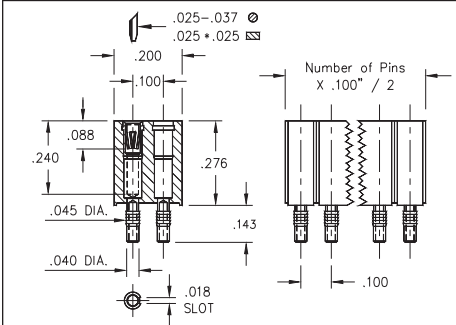
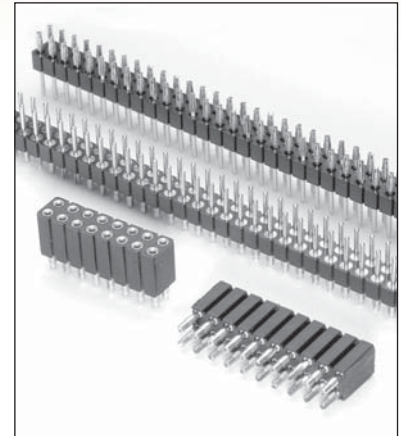

FIG. 4

- The unique compliant tail pins conform to .040"±.003" finished hole without stressing inner layers. Patent No. 4,799,904
- Headers and sockets are available for board thicknesses of .060" - .100" and .090" - .130". See ordering information for details
- Series 802 pin headers use MM #5601 and #5602 compliant tail pins featuring a .030" dia. mating lead. See page 220 for details
- Series 803 sockets with MM #4614 or #4615 pins use Hi-Rel, 6-finger BeCu #47 contact rated at 4.5 amps. Receptacles accept .030" diameter pins & .025" square pins. See pg. 256 for details
- Insulators are high temperature thermoplastic



ORDERING INFORMATION

FIG. 1	Compliant Tail Pin Header for .060" - .100" Thick Boards			
	802-XX-0__-61-001000 Specify number of pins ↑ 02-64			
FIG. 2	Compliant Tail Pin Header for .090" - .130" Thick Boards			
	802-XX-0__-62-001000 Specify number of pins ↑ 04-64			
<div style="display: flex; justify-content: space-around; align-items: center;"> <div style="border: 1px solid black; padding: 5px; background-color: #90EE90;">RoHS-2 2011/65/EU</div> <div style="border: 1px solid black; border-radius: 50%; padding: 5px;">XX=Plating Code See Below</div> <div style="border: 1px solid black; border-radius: 50%; padding: 5px;">For Electrical, Mechanical & Environmental Data, See page 264</div> </div>				
SPECIFY PLATING CODE XX=				
Pin Plating				
	10	90	40	
	10 μ" Au	200 μ" Sn/Pb	200 μ" Sn	

FIG. 3	Compliant Tail Socket for .060" - .100" Thick Boards							
	803-XX-__-61-001000 Specify number of pins ↑ 002-100							
FIG. 4	Compliant Tail Socket for .090" - .130" Thick Boards							
	803-XX-__-62-001000 Specify number of pins ↑ 004-100							
<div style="display: flex; justify-content: space-around; align-items: center;"> <div style="border: 1px solid black; padding: 5px; background-color: #90EE90;">RoHS-2 2011/65/EU</div> <div style="border: 1px solid black; border-radius: 50%; padding: 5px;">XX=Plating Code See Below</div> <div style="border: 1px solid black; border-radius: 50%; padding: 5px;">For Electrical, Mechanical & Environmental Data, See page 264</div> </div>								
SPECIFY PLATING CODE XX=								
Sleeve (Pin)								
Contact (Clip)								
	11	13	91	93	99	41	43	44
	10 μ" Au	10 μ" Au	200 μ" Sn/Pb	200 μ" Sn/Pb	200 μ" Sn/Pb	200 μ" Sn	200 μ" Sn	200 μ" Sn
	10 μ" Au	30 μ" Au	10 μ" Au	30 μ" Au	100 μ" Sn/Pb	10 μ" Au	30 μ" Au	100 μ" Sn



INTERCONNECTS

SERIES 800 & 802 • .100" GRID (.030" DIA. PINS), SHROUDED STRAIGHT, SURFACE MOUNT & SOLDERLESS PRESS-FIT • SINGLE AND DOUBLE ROW STRIPS

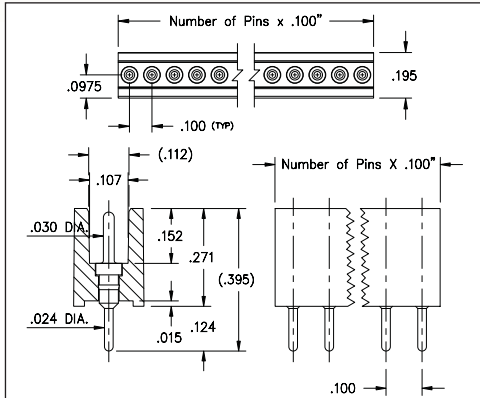

FIG. 1

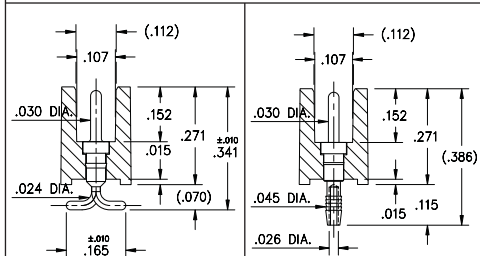

FIG. 2

FIG. 3

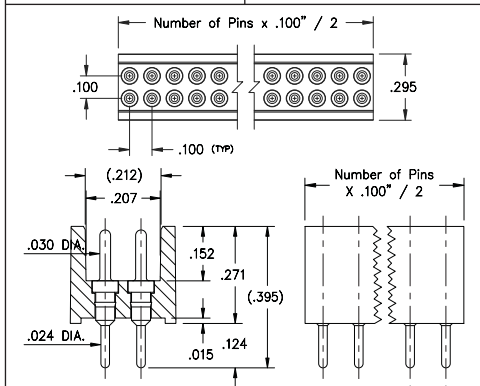

FIG. 4

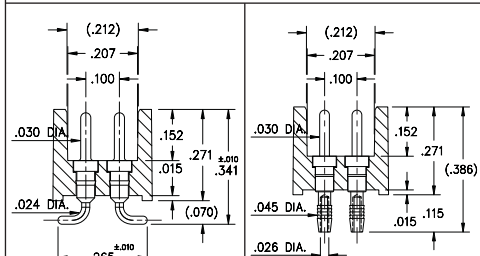





FIG. 5

FIG. 6

- Shrouded pin interconnects available with straight Series 800...10-052 and 802...10-052 or surface mount 800...30-052 and 802...30-052 use MM #5016 pins. See page 215 for details
- Shrouded pin interconnects with solderless press-fit Series 800...61-051 and 802...61-051 use MM #5607 pins. See page 213 for details. The unique compliant tail pins conform to .040" ± .003" finished hole without stressing inner layers. Patent No. 4,799,904
- Insulators are high temperature thermoplastic, suitable for all soldering operations



ORDERING INFORMATION

	Series 800...10-052	Straight Pin Header
FIG. 1	800-10-0_ -10-052000	Specify number of pins 01-32
FIG. 2	Series 800...30-052	Surface Mount Pin Header
	800-10-0_ -30-052000	Specify number of pins 03-32
FIG. 3	Series 800...61-051	Compliant Tail Pin Header
	800-10-0_ -61-051000	Specify number of pins 01-32
FIG. 4	Series 802...10-052	Straight Pin Header
	802-10-0_ -10-052000	Specify number of pins 04-64
FIG. 5	Series 802...30-052	Surface Mount Pin Header
	802-10-0_ -30-052000	Specify number of pins 04-64
FIG. 6	Series 802...61-051	Compliant Tail Pin Header
	802-10-0_ -61-051000	Specify number of pins 04-64
  		
SPECIFY PLATING CODE XX=		
Pin Plating 	10 ◇	
	10 μ" Au	



INTERCONNECTS

**SERIES 349, 449, 800, 801, 802, 803 • .100" GRID (.030" DIA. PINS),
SURFACE MOUNT HEADERS & SOCKETS • SINGLE AND DOUBLE ROW STRIPS**

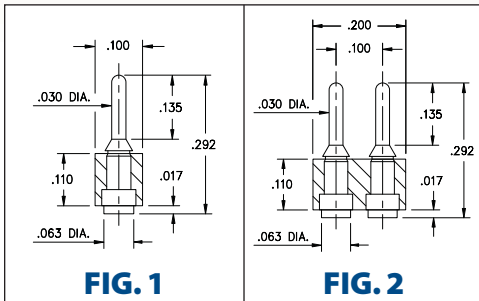

FIG. 1

FIG. 2

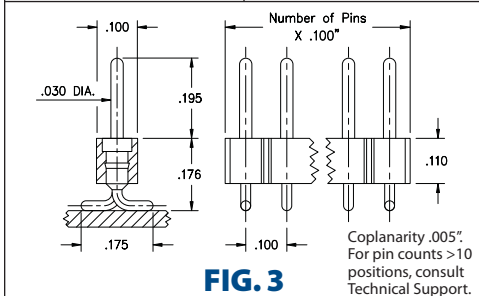

FIG. 3

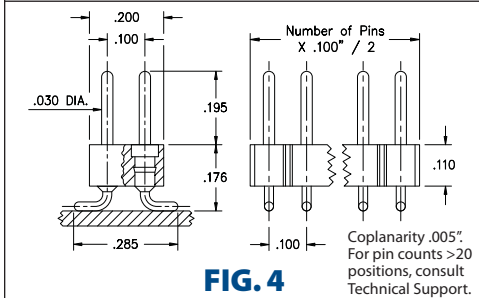

FIG. 4

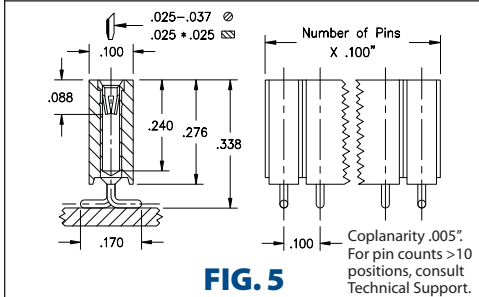

FIG. 5

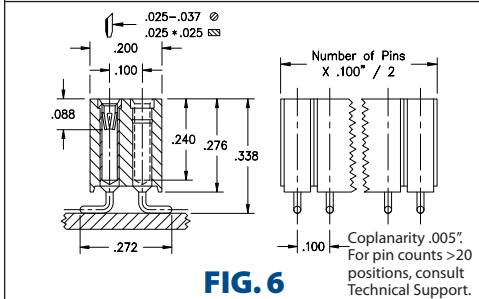
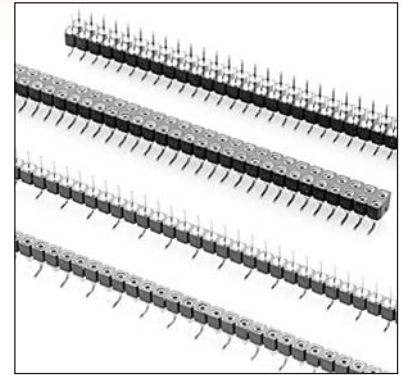

FIG. 6

- Series 349 & 449 use MM #4956-1 pins. See page 218 for details
- Series 800 & 802 use MM #7007 pins. See page 215 for details
- Series 801 & 803 use MM #1304 receptacles and accept pin diameters from .025"-.037" and .025" square pins. See page 177 for details
- Receptacles use Hi-Rel, 6-finger BeCu #47 contact rated at 4.5 amps. See page 256 for details
- Insulators are high temperature thermoplastic, suitable for all soldering operations



ORDERING INFORMATION

FIG. 1	Series 349...560	Single Row Surface Mount Header			
			349-10-1__-00-560000	Specify number of pins	02-64
FIG. 2	Series 449...560	Double Row Surface Mount Header			
			449-10-2__-00-560000	Specify number of pins	04-64
FIG. 3	Series 800...001	Single Row Surface Mount Header			
			800-10-0__-30-001000	Specify number of pins	03-64
FIG. 4	Series 802...001	Double Row Surface Mount Header			
			802-10-0__-30-001000	Specify number of pins	04-72
SPECIFY PLATING CODE XX=			10		
Pin Plating			10 μ" Au		
FIG. 5	Series 801...001	Single Row Surface Mount Socket			
			801-43-0__-30-001000	Specify number of pins	03-50
FIG. 6	Series 803...001	Double Row Surface Mount Socket			
			803-XX-__-30-001000	Specify number of pins	004-100
		RoHS-2			
		2011/65/EU			
		XX=Plating Code			
		See Below			
		For Electrical, Mechanical & Environmental Data,			
		See page 264			
SPECIFY PLATING CODE XX=			93		43
Sleeve (Pin)			200 μ" Sn/Pb		200 μ" Sn
Contact (Clip)			30 μ" Au		30 μ" Au



INTERCONNECTS

SERIES 804 & 805 • .100" GRID (.030" DIA. PINS), HEADERS AND SOCKETS • TRIPLE ROW

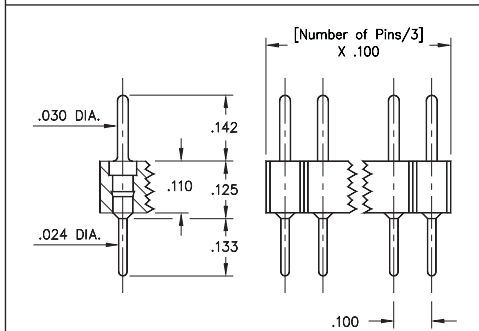
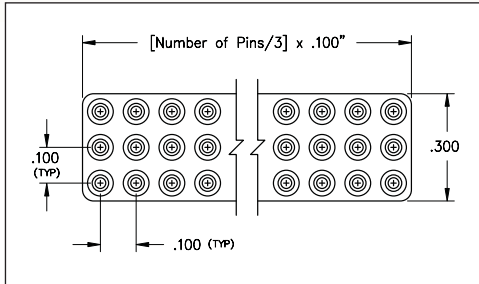

FIG. 1

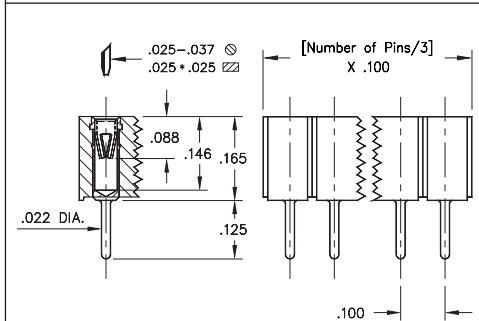
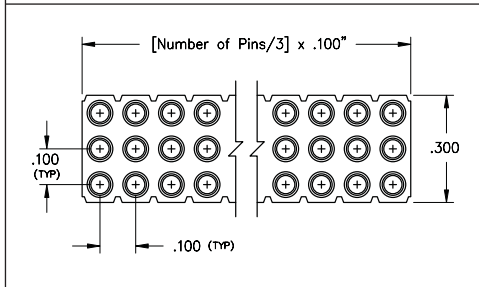
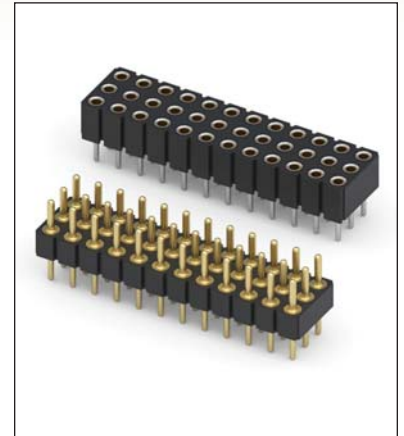

FIG. 2

- Series 804 triple row .100" grid headers uses MM #5016 pins. See page 215 for details
- Series 805 triple row .100" grid sockets uses MM #1303 pins. See page 180 for details
- Series 805 triple row .100" grid sockets uses Hi-Rel, 6-finger BeCu #47 contact rated at 4.5 amps. See page 256 for details
- Insulators are high temperature thermoplastic, suitable for all soldering operations



ORDERING INFORMATION

FIG. 1	Series 804...002	Straight Pin Header			
	804-10-0	-10-002000	Specify number of pins		
			09-96		
	RoHS - 2 2011/65/EU	XX=Plating Code See Below	For Electrical, Mechanical & Environmental Data, See page 264		
	SPECIFY PLATING CODE XX=	10			
	Pin Plating	10 μ" Au			

FIG. 2	Series 805...012	Straight Pin Socket			
	805-43-0	-10-012000	Specify number of pins		
			09-96		
	RoHS - 2 2011/65/EU	XX=Plating Code See Below	For Electrical, Mechanical & Environmental Data, See page 264		
	SPECIFY PLATING CODE XX=				43
	Sleeve (Pin)				200 μ" Sn
	Contact (Clip)				30 μ" Au



INTERCONNECTS

SERIES 800, 801, 802, 803 • .100" GRID SOLDER CUP HEADERS AND SOCKETS • SINGLE AND DOUBLE ROW STRIPS

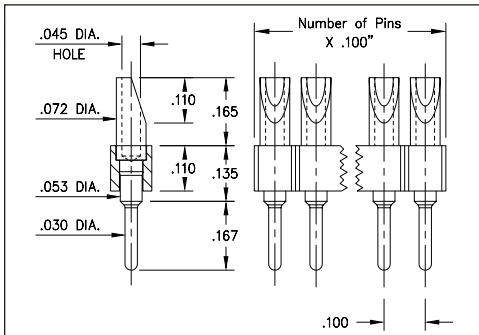

FIG. 1

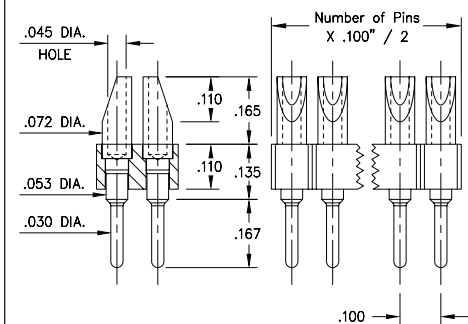

FIG. 2

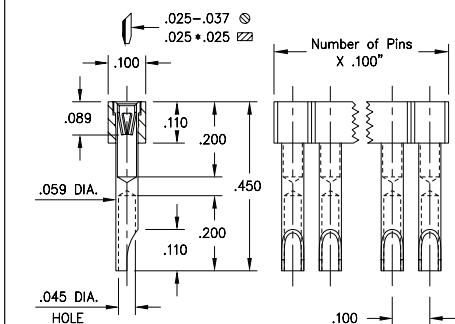

FIG. 3

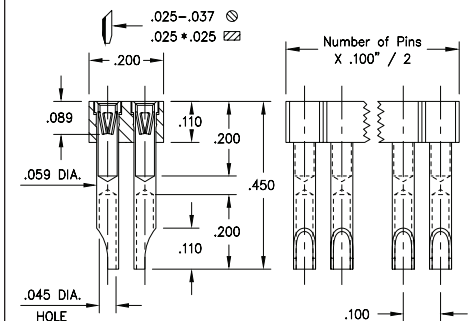
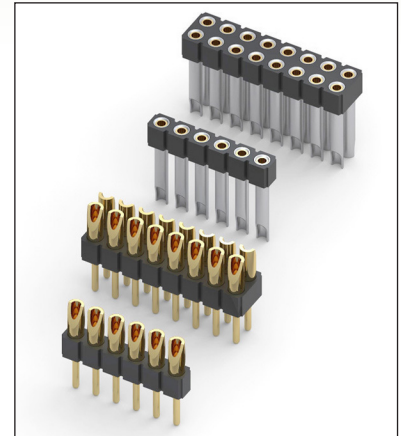

FIG. 4

- Series 800 and 802 use MM #1107 pins. See page 218 for details
- Series 801 and 803 use MM #1134 pin receptacles and accept pin diameters from .025"-.037" and .025" square pins. See page 177 for details
- Series 801 and 803 receptacles use Hi-Rel, 4-finger BeCu #47 contact rated at 4.5 amps. See page 256 for details
- Solder cups are pre-aligned and accept up to 20 AWG wire
- Insulators are high temperature thermoplastic, suitable for all soldering operations



ORDERING INFORMATION

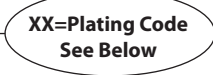





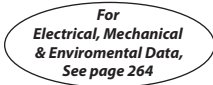



FIG. 1	Series 800...007	Single Row Solder Cup / Solder Tail	
	800-XX-0	-10-007000	02-64
Specify number of pins			
FIG. 2	Series 802...007	Double Row Solder Cup / Solder Tail	
	802-XX-0	-10-007000	02-64
Specify number of pins			
  			
SPECIFY PLATING CODE XX=		10 	40 
Pin Plating 		10 μ" Au	200 μ" Sn

FIG. 3	Series 801...007	Single Row Solder Cup Sockets	
	801-13-0	-10-007000	02-64
Specify number of pins			
FIG. 4	Series 803...007	Double Row Solder Cup Sockets	
	803-13-0	-10-007000	02-64
Specify number of pins			
  			
SPECIFY PLATING CODE XX=		13 	
Sleeve (Pin) 		10 μ" Au	
Contact (Clip) 		30 μ" Au	



INTERCONNECTS

SERIES 800, 801, 802, 803 • .100" GRID (.040" DIA. PINS), HEADERS AND SOCKETS • SINGLE AND DOUBLE ROW STRIPS

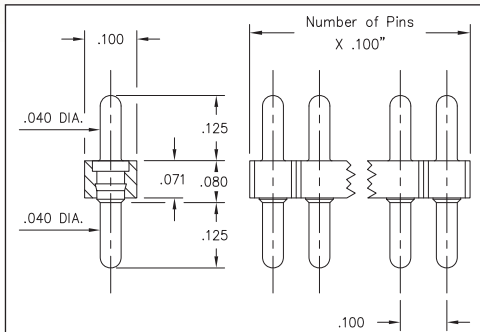

FIG. 1

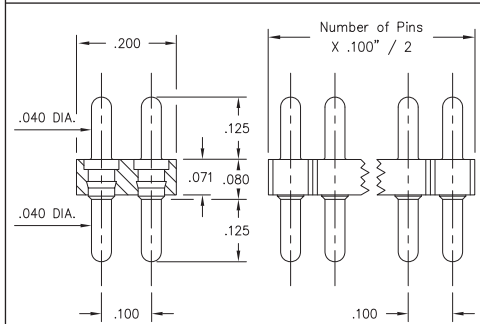

FIG. 2

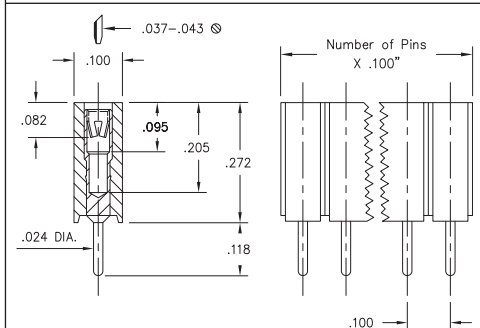

FIG. 3

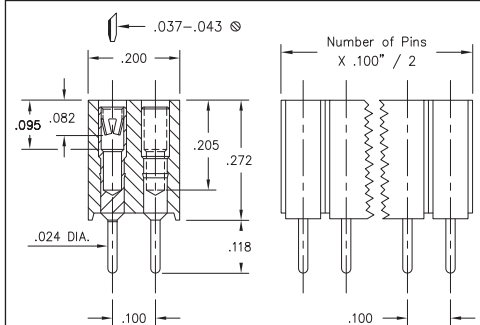
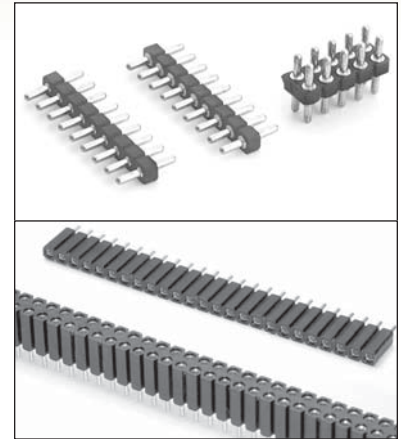

FIG. 4

- Series 800 and 802 single and double row interconnects feature sturdy .040" dia. leads (MM #3077) and low profile (.071" thick) insulator. See page 215 for details
- Series 801 and 803 single and double row sockets use MM #1313 receptacles. See page 181 for details
- Series 801 and 803 receptacles use Hi-Rel, 6-finger BeCu #18 contact rated at 8 amps. Receptacles accept .037"-.043" diameter pins. See page 257 for details
- Insulators are high temperature thermoplastic, suitable for all soldering operations



ORDERING INFORMATION

FIG. 1	Series 800...10-004	Single Row Pin Header		
	800-XX-0	-10-004000	Specify number of pins 01-50	
FIG. 2	Series 802...10-004	Double Row Pin Header		
	802-XX-	-10-004000	Specify number of pins 004-100	
XX=Plating Code See Below For Electrical, Mechanical & Environmental Data, See page 264				
SPECIFY PLATING CODE XX=		10	90	40
Pin Plating		10 μ" Au	200 μ" Sn/Pb	200 μ" Sn

FIG. 3	Series 801...10-004	Single Row Socket						
	801-XX-0	-10-004000	Specify number of pins 01-50					
FIG. 4	Series 803...10-004	Double Row Socket						
	803-XX-	-10-004000	Specify number of pins 004-100					
XX=Plating Code See Below For Electrical, Mechanical & Environmental Data, See page 264								
SPECIFY PLATING CODE XX=		13	91	93	99	41	43	44
Sleeve (Pin)		10 μ" Au	200 μ" Sn/Pb	200 μ" Sn/Pb	200 μ" Sn/Pb	200 μ" Sn	200 μ" Sn	200 μ" Sn
Contact (Clip)		30 μ" Au	10 μ" Au	30 μ" Au	100 μ" Sn/Pb	10 μ" Au	30 μ" Au	100 μ" Sn



INTERCONNECTS

SERIES 834 & 835 • .100" GRID OFP® PASS-THROUGH SOCKETS Ø.030" & □.025" PINS • SINGLE AND DOUBLE ROW STRIPS

- 834/835 Series Pass-Through Sockets have a low .130" profile and will accept Ø.030" round pin, as well as industry standard .025" square pin headers.
- They are typically used to interconnect two or more parallel circuit boards.
- Sockets are designed for hand, wave or reflow* soldering. The high temperature insulator is compatible with all solder processes.
- Unique ORGANIC FIBRE PLUG® barriers prevent solder, paste or flux from contaminating the internal spring contacts. After soldering, the OFP® barriers are pushed out of the socket when the mating header is inserted.
- Mill-Max sockets use a receptacle consisting of a precision-machined brass sleeve with a press-fit beryllium copper "multi-finger" spring contact.
- Recommended mounting holes are Ø.046 ±.003" PTH (1,2 mm drilled prior to plating).

*Intrusive reflow (also called "pin-in-paste") is a technique of using conventional through-hole components in a reflow soldering process. The pass-through socket is placed into plated through-holes in the circuit board (solder paste has previously been screen printed on pads adjacent to the holes) and the board is reflowed in the same pass as other SMT components. Solder will fill the plated through-holes and achieve solder joints as reliable as wave soldering. The OFP® barrier prevents solder paste from being picked up inside the contact during assembly.

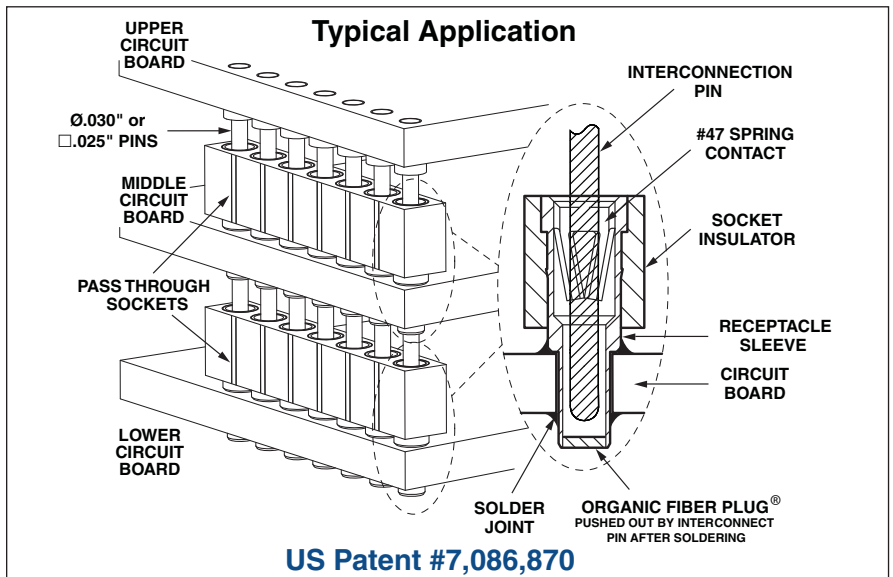
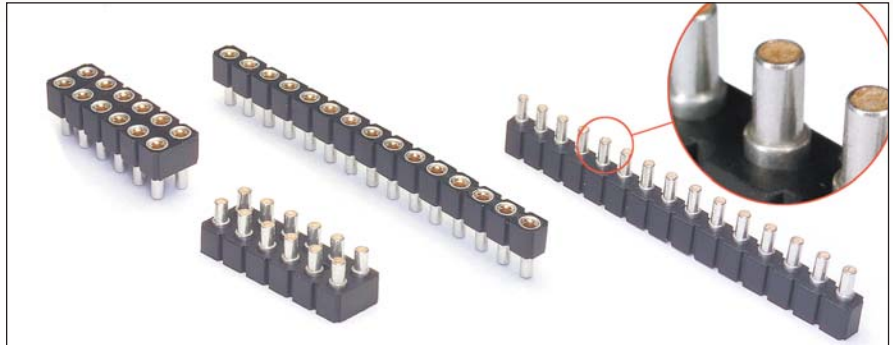

ORDERING INFORMATION

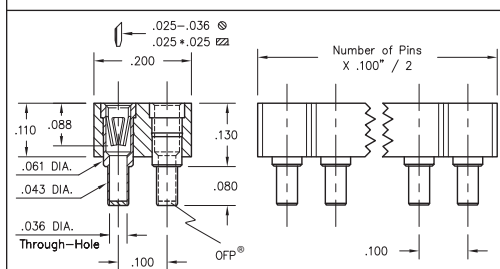
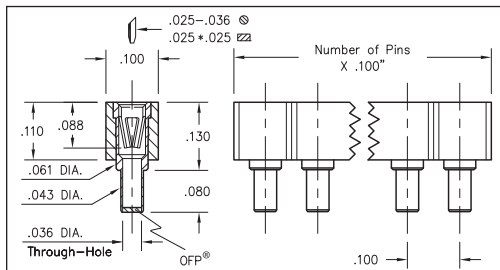

FIG. 1	Series 834...001 Single Row OFP® Pass-Through Socket	834-XX-0 -10-001000
	Specify number of pins	01-64
FIG. 2	Series 835...001 Double Row OFP® Pass-Through Socket	835-XX-0 -10-001000
	Specify number of pins	04-72
<div style="display: flex; justify-content: space-around; align-items: center;"> <div style="border: 1px solid green; padding: 5px; color: green; font-weight: bold;">RoHS-2 2011/65/EU</div> <div style="border: 1px solid black; border-radius: 50%; padding: 5px;">XX=Plating Code See Below</div> <div style="border: 1px solid black; border-radius: 50%; padding: 5px; text-align: center;">For Electrical, Mechanical & Environmental Data, See page 264</div> </div>		
SPECIFY PLATING CODE XX=		93
Sleeve (Pin)		200 µ" Sn/Pb
Contact (Clip)		30 µ" Au
		43
		200 µ" Sn
		30 µ" Au



INTERCONNECTS

SERIES 800 & 801 • .200" GRID (.030" DIA. PINS), STRAIGHT AND RIGHT ANGLE • SINGLE ROW STRIPS

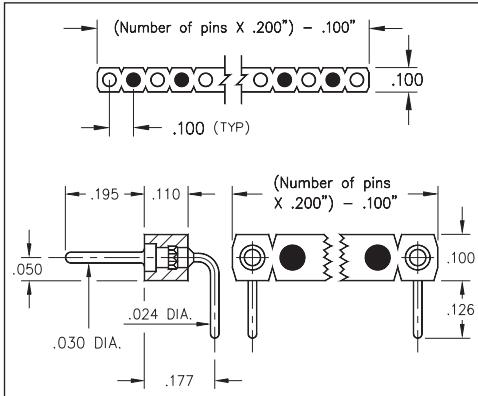

FIG. 1

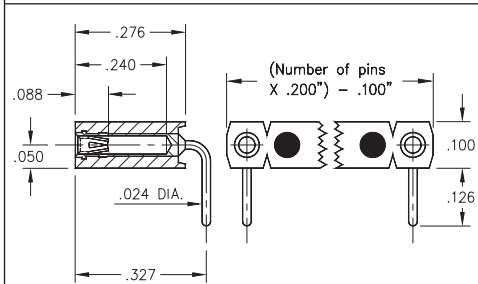

FIG. 2

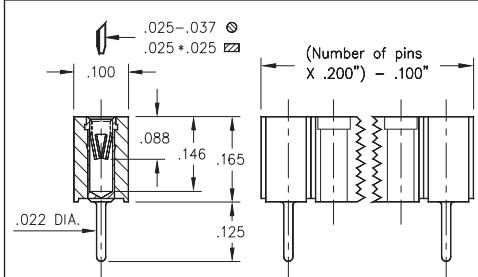

FIG. 3

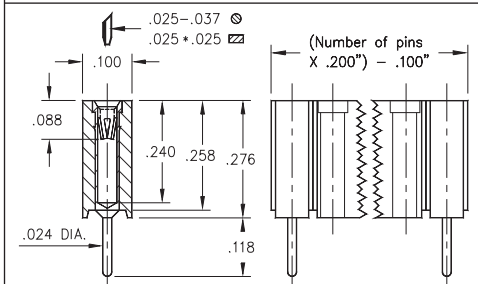
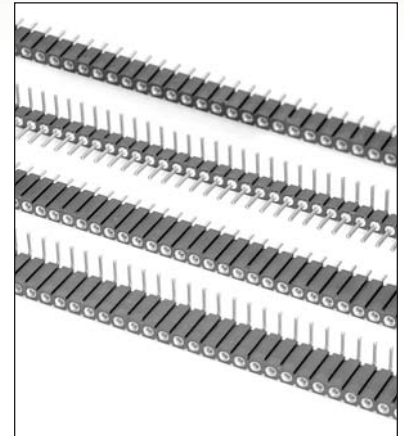

FIG. 4

- Series 800 selectively loaded headers uses MM #5005 pins. See page 215 for details
- Series 801 selectively loaded sockets use MM #1303, #1304 and #1305 pins. See pages 177, 179 & 180 for details
- Series 801 selectively loaded sockets use Hi-Rel, 6-finger BeCu #47 contact rated at 3 amps. See page 256 for details
- Insulators are high temperature thermoplastic, suitable for all soldering operations



ORDERING INFORMATION

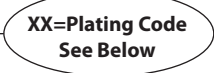
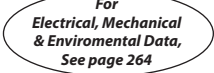



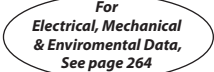



FIG. 1	Series 800...20-201	Right Angle Header
	800-10-0	-20-201000
	Specify number of pins	02-32
  		
SPECIFY PLATING CODE XX=	10 	
Pin Plating 	10 μ" Au	

FIG. 2	Series 801...20-201	Right Angle Socket
	801-XX-0	-20-201000
	Specify number of pins	02-25
FIG. 3	Series 801...10-212	Straight Socket
	801-43-0	-10-212000
	Specify number of pins	02-18
FIG. 4	Series 801...10-201	Straight Socket
	801-43-0	-10-201000
	Specify number of pins	02-25
  		
SPECIFY PLATING CODE XX=	41 	43 
Sleeve (Pin) 	200 μ" Sn	200 μ" Sn
Contact (Clip) 	10 μ" Au	30 μ" Au



INTERCONNECTS

SERIES 310, 311, 315 • .100" GRID SOLDER TAIL • SINGLE ROW STRIPS

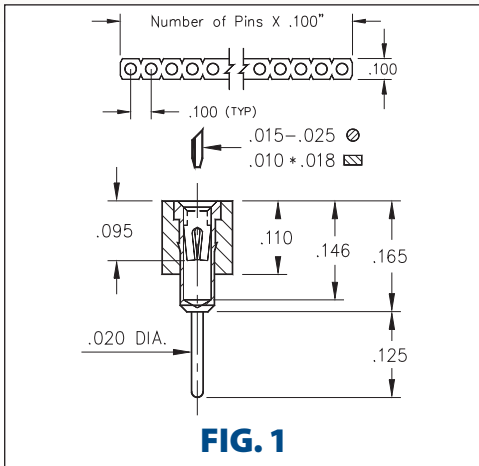

FIG. 1

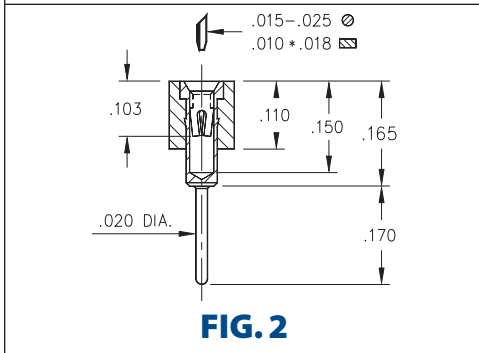

FIG. 2

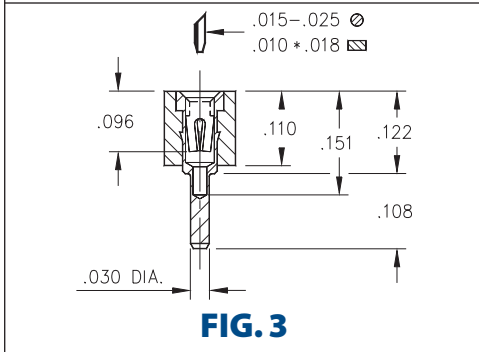

FIG. 3

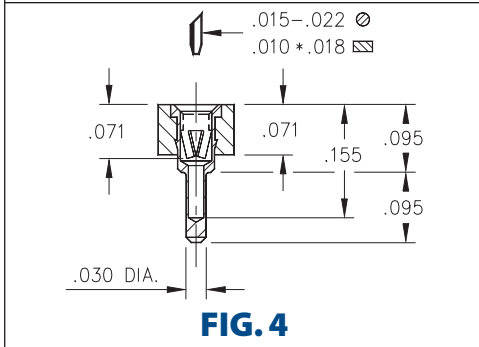

FIG. 4

- SIP sockets accept .015 - .025" diameter pins and standard IC leads
- Various solder tails available: standard length, long for multi-layer boards, very low and ultra low profile. See Mill-Max #1001, #0134, #0501 or #1534 pins. See pages 161, 162 and 165 for details
- Hi-Rel, 4-finger BeCu #12 and #30 contact are rated at 3 amps. See pages 252 and 253 for details
- Insulators are high temperature thermoplastic, suitable for all soldering operations



ORDERING INFORMATION

	Series 310...001	Standard Solder Tail
FIG. 1	310-XX-1	-41-001000 Specify number of pins 01-64
FIG. 2	Series 311...001	Long Solder Tail
	311-XX-1	-41-001000 Specify number of pins 01-64
FIG. 3	Series 315...001	Very Low Profile
	315-XX-1	-41-001000 Specify number of pins 01-64
FIG. 4	Series 315...003	Ultra Low Profile
	315-XX-1	-41-003000 Specify number of pins 01-64

--	--	--

SPECIFY PLATING CODE XX=	11	13	91	93	99	41	43	44
Sleeve (Pin)	10 μ" Au	10 μ" Au	200 μ" Sn/Pb	200 μ" Sn/Pb	200 μ" Sn/Pb	200 μ" Sn	200 μ" Sn	200 μ" Sn
Contact (Clip)	10 μ" Au	30 μ" Au	10 μ" Au	30 μ" Au	100 μ" Sn/Pb	10 μ" Au	30 μ" Au	100 μ" Sn

★ 41 & 91 Platings Non-Standard



INTERCONNECTS

SERIES 410, 411, 415 • .100" GRID SOLDER TAIL • DOUBLE ROW STRIPS

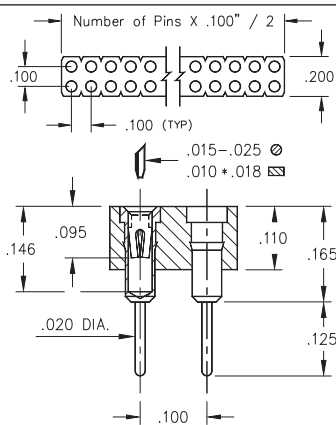

FIG. 1

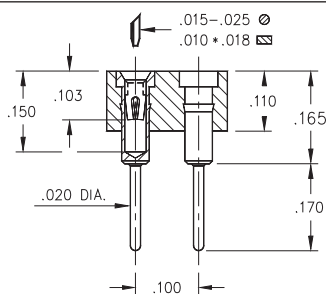

FIG. 2

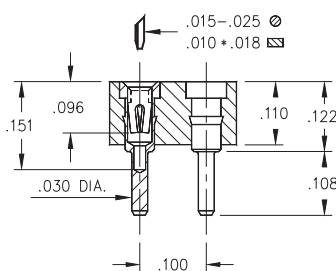

FIG. 3

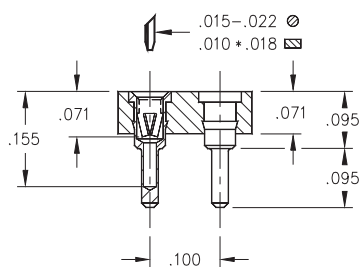

FIG. 4

- Series 41X double row strip sockets are on .100" grid
- Various solder tails available: standard length, long for multi-layer boards, very low and ultra low profile. See Mill-Max #1001, #0134, #0501 or #1534 pins. See pages 161, 162 and 165 for details
- Hi-Rel, 4-finger BeCu #12 and #30 contact are rated at 3 amps. See pages 252 and 253 for details
- Insulators are high temperature thermoplastic, suitable for all soldering operations



ORDERING INFORMATION

	Series 410...001	Standard Solder Tail					
FIG. 1	410-XX-2	-41-001000 Specify number of pins → 04-64					
	Series 411...001	Long Solder Tail					
FIG. 2	411-XX-2	-41-001000 Specify number of pins → 04-64					
	Series 415...001	Very Low Profile					
FIG. 3	415-XX-2	-41-001000 Specify number of pins → 04-64					
	Series 415...003	Ultra Low Profile					
FIG. 4	415-XX-2	-41-003000 Specify number of pins → 04-64					
<div style="display: flex; justify-content: space-around; align-items: center;"> <div style="border: 1px solid black; padding: 5px; background-color: #90EE90;">RoHS-2 2011/65/EU</div> <div style="border: 1px solid black; border-radius: 50%; padding: 5px;">XX=Plating Code See Below</div> <div style="border: 1px solid black; border-radius: 50%; padding: 5px;">For Electrical, Mechanical & Environmental Data, See page 264</div> </div>							
SPECIFY PLATING CODE XX=							
	11	13	91	93	41	43	
Sleeve (Pin)	10 μ" Au	10 μ" Au	200 μ" Sn/Pb	200 μ" Sn/Pb	200 μ" Sn	200 μ" Sn	
Contact (Clip)	10 μ" Au	30 μ" Au	10 μ" Au	30 μ" Au	10 μ" Au	30 μ" Au	



INTERCONNECTS

SERIES 316 • .100" GRID ELEVATED • SINGLE ROW STRIPS

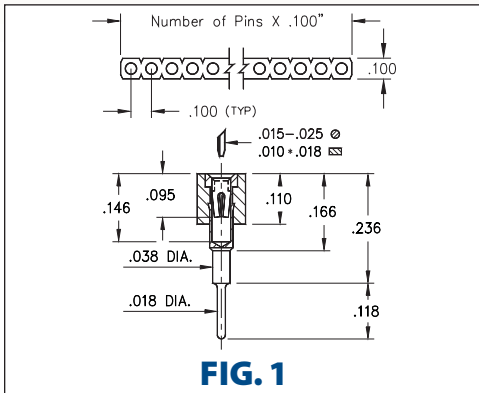

FIG. 1

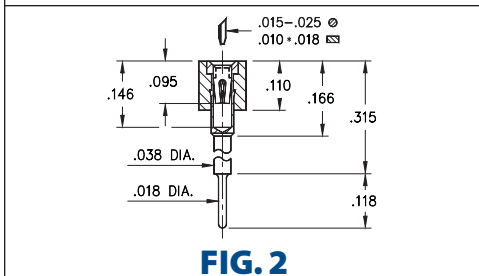

FIG. 2

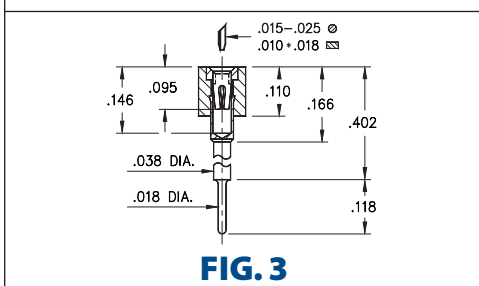

FIG. 3

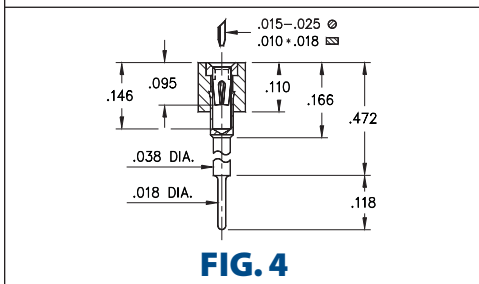

FIG. 4

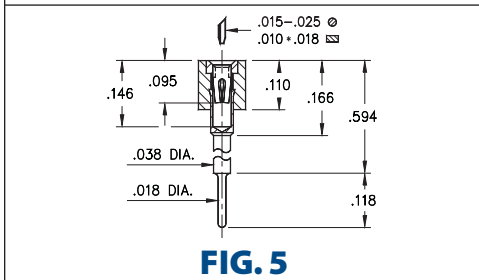

FIG. 5

- Elevated socket strips are available in 5 different heights:

316...006 uses pin # 0153-1
 316...003 uses pin # 0153-2
 316...007 uses pin # 0153-3
 316...008 uses pin # 0153-4
 316...001 uses pin # 0153-5
 See page 167 for details

- Hi-Rel, 4-finger BeCu #30 contact is rated at 3 amps. See page 253 for details

- Insulators are high temperature thermoplastic, suitable for all soldering operations

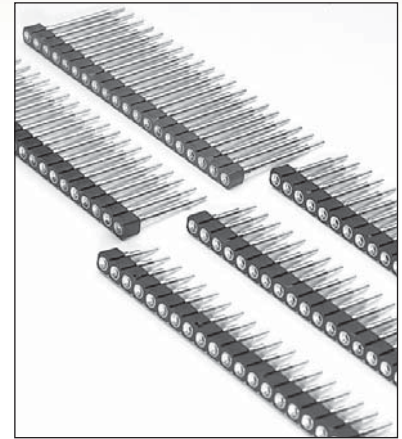

ORDERING INFORMATION

	Series 316...006	Standoff Height = .236
FIG. 1	316-XX-1	-41-006000
	Specify number of pins	01-64
	Series 316...003	Standoff Height = .315
FIG. 2	316-XX-1	-41-003000
	Specify number of pins	01-64
	Series 316...007	Standoff Height = .402
FIG. 3	316-XX-1	-41-007000
	Specify number of pins	01-64
	Series 316...008	Standoff Height = .472
FIG. 4	316-XX-1	-41-008000
	Specify number of pins	01-64
	Series 316...001	Standoff Height = .594
FIG. 5	316-XX-1	-41-001000
	Specify number of pins	01-64



XX=Plating Code
See Below

For Electrical, Mechanical & Environmental Data, See page 264

SPECIFY PLATING CODE XX=	91	93	41	43
Sleeve (Pin)	200 μ" Sn/Pb	200 μ" Sn/Pb	200 μ" Sn	200 μ" Sn
Contact (Clip)	10 μ" Au	30 μ" Au	10 μ" Au	30 μ" Au



INTERCONNECTS

SERIES 416 • .100" GRID ELEVATED • DOUBLE ROW STRIPS

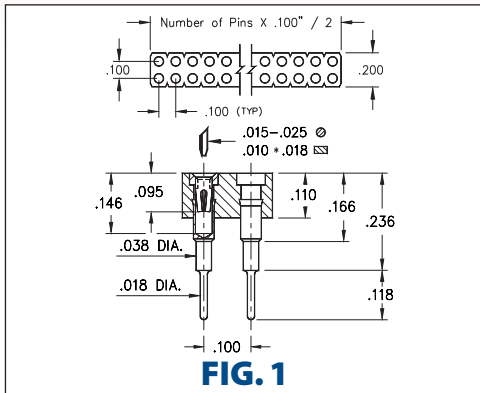

FIG. 1

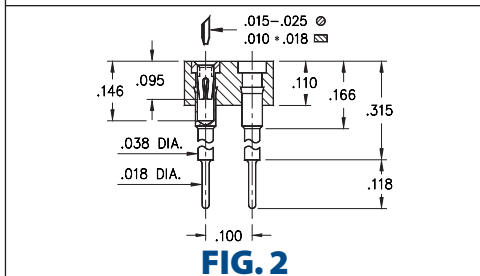

FIG. 2

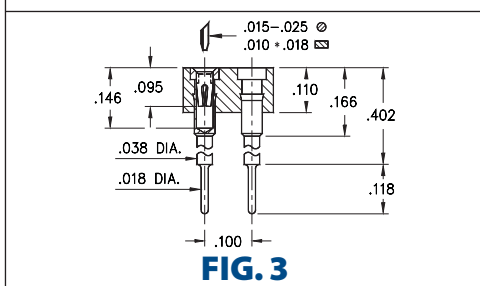

FIG. 3

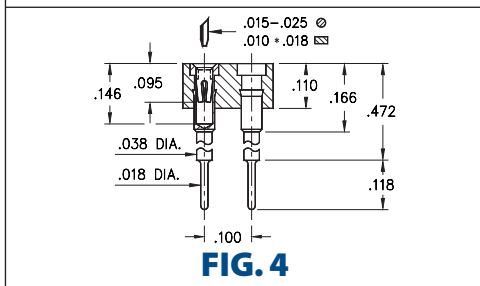

FIG. 4

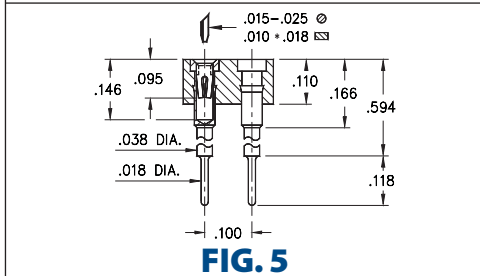

FIG. 5

- Elevated socket strips are available in 5 different heights:

- 416...006 uses pin # 0153-1
 - 416...003 uses pin # 0153-2
 - 416...007 uses pin # 0153-3
 - 416...008 uses pin # 0153-4
 - 416...001 uses pin # 0153-5
- See page 167 for details

- Hi-Rel, 4-finger BeCu #30 contact is rated at 3 amps. See page 253 for details

- Insulators are high temperature thermoplastic, suitable for all soldering operations



ORDERING INFORMATION

	Series 416...006	Standoff Height = .236
FIG. 1	416-XX-2	-41-006000
	Specify number of pins	04-64
FIG. 2	Series 416...003	Standoff Height = .315
	416-XX-2	-41-003000
FIG. 3	Series 416...007	Standoff Height = .402
	416-XX-2	-41-007000
FIG. 4	Series 416...008	Standoff Height = .472
	416-XX-2	-41-008000
FIG. 5	Series 416...001	Standoff Height = .594
	416-XX-2	-41-001000



XX=Plating Code
See Below

For
Electrical, Mechanical
& Environmental Data,
See page 264

SPECIFY PLATING CODE XX=	91	93	41	43
Sleeve (Pin)	200 μ"Sn/Pb	200 μ"Sn/Pb	200 μ"Sn	200 μ"Sn
Contact (Clip)	10 μ"Au	30 μ"Au	10 μ"Au	30 μ"Au



INTERCONNECTS

SERIES 321, 322, 323, 324 • .100" GRID WRAPOST • SINGLE ROW STRIPS

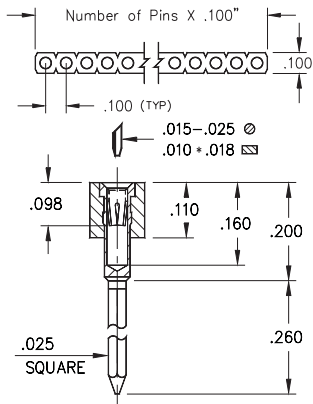

FIG. 1

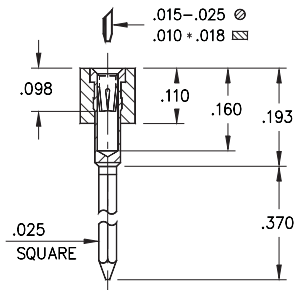

FIG. 2

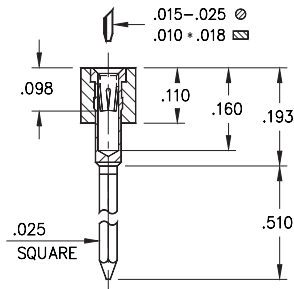

FIG. 3

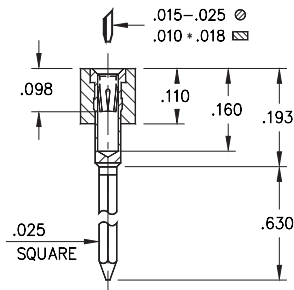

FIG. 4

• Wraposts available in 1 - 4 levels using MM pin numbers:

- 1-Level uses pin # 0040-1
 - 2-Level uses pin # 0089-2
 - 3-Level uses pin # 0088-3
 - 4-Level uses pin # 0086-4
- See page 198 for details

• Hi-Rel, 4-finger BeCu #30 contact is rated at 3 amps. See page 253 for details

• Insulators are high temperature thermoplastic, suitable for all soldering operations

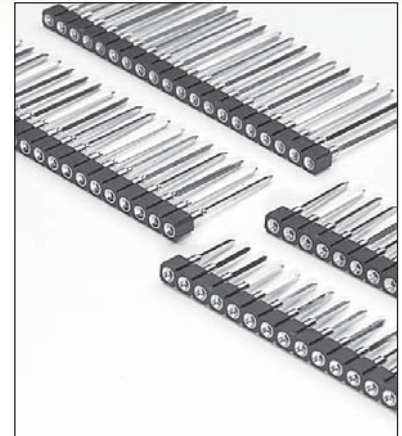

ORDERING INFORMATION

	Series 321...001	1 Level Wrapost					
FIG. 1	321-13-1	-41-001000 ↑ Specify number of pins 01-64					
	Series 322...001	2 Level Wrapost					
FIG. 2	322-XX-1	-41-001000 ↑ Specify number of pins 01-64					
	Series 323...001	3 Level Wrapost					
FIG. 3	323-XX-1	-41-001000 ↑ Specify number of pins 01-64					
	Series 324...002	4 Level Wrapost					
FIG. 4	324-XX-1	-41-002000 ↑ Specify number of pins 01-64					
<div style="display: flex; justify-content: space-around; align-items: center;"> <div style="border: 1px solid black; padding: 5px; background-color: #90EE90;">RoHS-2 2011/65/EU</div> <div style="border: 1px solid black; border-radius: 50%; padding: 5px;">XX=Plating Code See Below</div> <div style="border: 1px solid black; border-radius: 50%; padding: 5px;">For Electrical, Mechanical & Environmental Data, See page 264</div> </div>							
SPECIFY PLATING CODE XX=							
Sleeve (Pin)	11 ◆	13 ◆	91	93	41 ◆	43 ◆	
Contact (Clip)	10 μ" Au	10 μ" Au	200 μ" Sn/Pb	200 μ" Sn/Pb	200 μ" Sn	200 μ" Sn	
	10 μ" Au	30 μ" Au	10 μ" Au	30 μ" Au	10 μ" Au	30 μ" Au	



INTERCONNECTS

SERIES 421, 422, 423, 424 • .100" GRID WRAPPOST • DOUBLE ROW STRIPS

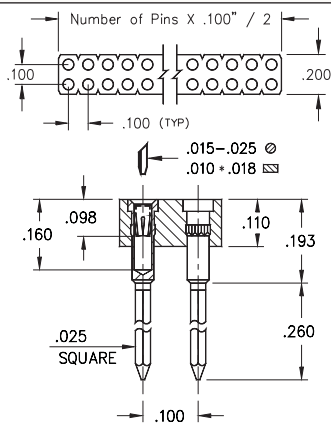

FIG. 1

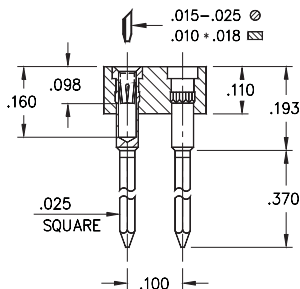

FIG. 2

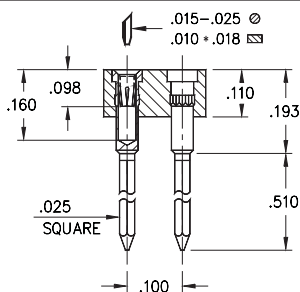

FIG. 3

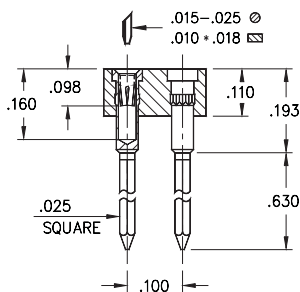

FIG. 4

- Wrappost double row strip sockets are available with 1 - 4 level wrapposts:

- 1-Level uses pin # 0040-1
 - 2-Level uses pin # 0089-2
 - 3-Level uses pin # 0088-3
 - 4-Level uses pin # 0086-4
- See page 198 for details

- Hi-Rel, 4-finger BeCu #30 contact is rated at 3 amps. See page 253 for details

- Insulators are high temperature thermoplastic, suitable for all soldering operations



ORDERING INFORMATION

	Series 421...001	1 Level Wrappost
FIG. 1	421-XX-2	-41-001000 Specify number of pins → 04-64
	Series 422...001	2 Level Wrappost
FIG. 2	422-XX-2	-41-001000 Specify number of pins → 04-64
	Series 423...001	3 Level Wrappost
FIG. 3	423-XX-2	-41-001000 Specify number of pins → 04-64
	Series 424...002	4 Level Wrappost
FIG. 4	424-XX-2	-41-002000 Specify number of pins → 04-64
<div style="display: flex; justify-content: space-around; align-items: center;"> <div style="border: 1px solid black; padding: 5px; background-color: #90EE90;">RoHS-2 2011/65/EU</div> <div style="border: 1px solid black; border-radius: 50%; padding: 5px;">XX=Plating Code See Below</div> <div style="border: 1px solid black; border-radius: 50%; padding: 5px;">For Electrical, Mechanical & Environmental Data, See page 264</div> </div>		
SPECIFY PLATING CODE XX=		
	13	93
Sleeve (Pin)	10 μ" Au	200 μ" Sn/Pb
Contact (Clip)	30 μ" Au	30 μ" Au
		43
		200 μ" Sn
		30 μ" Au



INTERCONNECTS

SERIES 326 • .100" GRID WRAPOST WITH SOLDER TAIL • SINGLE ROW STRIPS

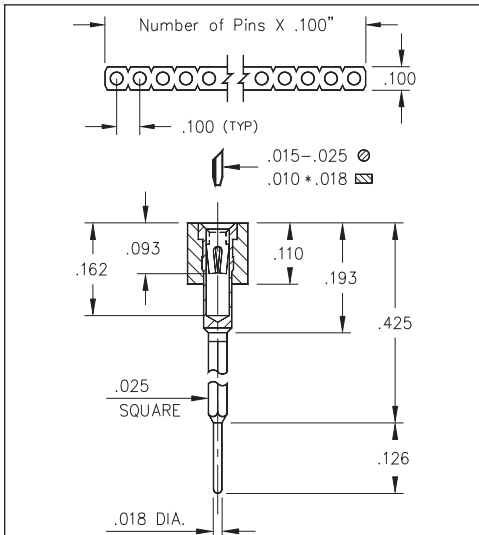

FIG. 1

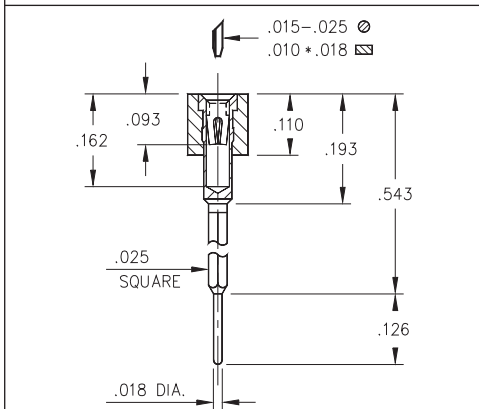

FIG. 2

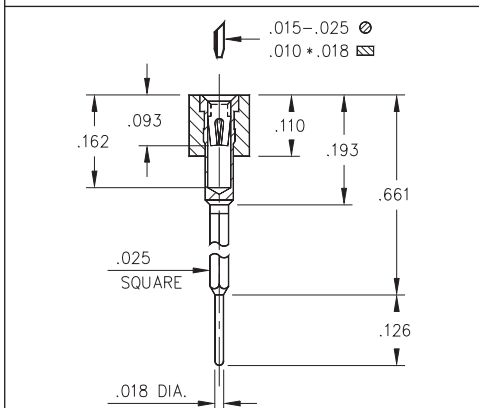

FIG. 3

- Wrapost / Solder Tail combinations are available in 3 lengths using MM pin numbers:

326...001 uses pin # 2601

326...002 uses pin # 2602

326...003 uses pin # 2603

See page 199 for details

- Hi-Rel, 4-finger BeCu #30 contact is rated at 3 amps. See page 253 for details

- Insulators are high temperature thermoplastic, suitable for all soldering operations

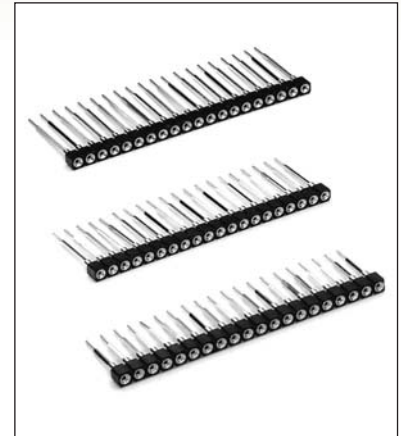

ORDERING INFORMATION

	Series 326...001	1 Level Wrapost
FIG. 1	326-XX-1	-41-001000
	Specify number of pins	01-64
FIG. 2	Series 326...002	2 Level Wrapost
	326-XX-1	-41-002000
	Specify number of pins	01-64
FIG. 3	Series 326...003	3 Level Wrapost
	326-XX-1	-41-003000
	Specify number of pins	01-64



XX=Plating Code
See Below

For
Electrical, Mechanical
& Environmental Data,
See page 264

SPECIFY PLATING CODE XX=	91	93	41	43
Sleeve (Pin)	200 μ" Sn/Pb	200 μ" Sn/Pb	200 μ" Sn	200 μ" Sn
Contact (Clip)	10 μ" Au	30 μ" Au	10 μ" Au	30 μ" Au



INTERCONNECTS

SERIES 426 • .100" GRID WRAPOST WITH SOLDER TAIL • DOUBLE ROW STRIPS

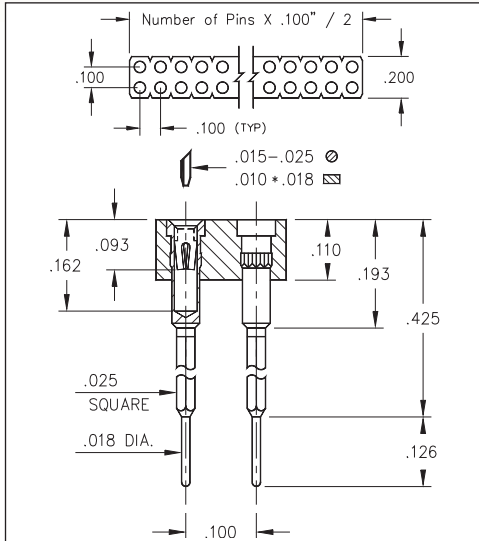

FIG. 1

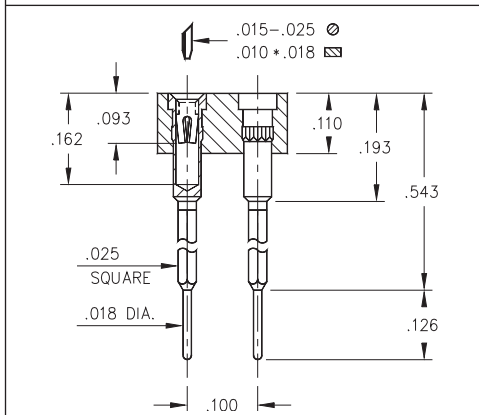

FIG. 2

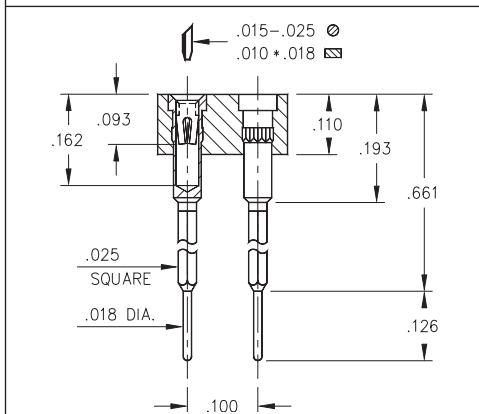

FIG. 3

- Wrapost / Solder Tail combination for interconnect purposes are available in 3 lengths using pin numbers:

426...001 uses pin # 2601
 426...002 uses pin # 2602
 426...003 uses pin # 2603
 See page 199 for details

- Hi-Rel, 4-finger BeCu #30 contact is rated at 3 amps. See page 253 for details

- Insulators are high temperature thermoplastic, suitable for all soldering operations



ORDERING INFORMATION

	Series 426...001	1 Level Wrapost
FIG. 1	426-XX-2	-41-001000
	Specify number of pins	04-64
	Series 426...002	2 Level Wrapost
FIG. 2	426-XX-2	-41-002000
	Specify number of pins	04-64
	Series 426...003	3 Level Wrapost
FIG. 3	426-XX-2	-41-003000
	Specify number of pins	04-64



XX=Plating Code
See Below

For
Electrical, Mechanical
& Environmental Data,
See page 264

SPECIFY PLATING CODE XX=	13	93	43
Sleeve (Pin)	10 μ" Au	200 μ" Sn/Pb	200 μ" Sn
Contact (Clip)	30 μ" Au	30 μ" Au	30 μ" Au



INTERCONNECTS

SERIES 304, 346 • .100" GRID SOLDERLESS PRESS-FIT • SINGLE ROW STRIPS

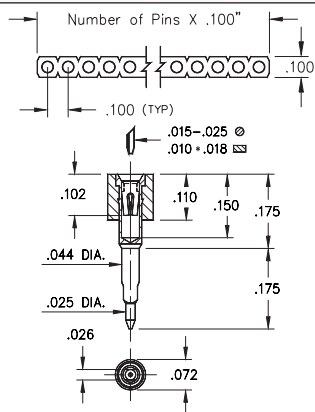

FIG. 1

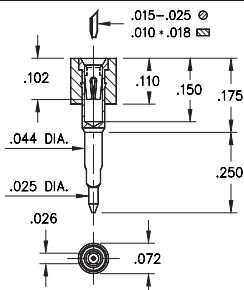

FIG. 2

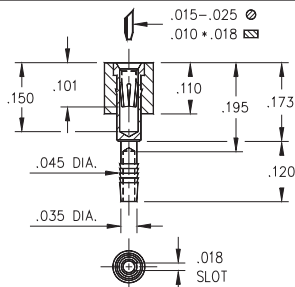

FIG. 3

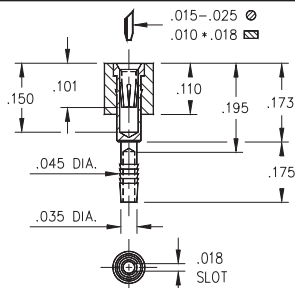

FIG. 4

- Unique compliant tail pins conform to the plated through-hole without stressing the inner layers of a multilayer board
- Recommended plated through-hole for 304 series: .036"-.041" use a 1.1mm drill prior to plating. Using MM #0477 & #0478 pins. See page 162 for details
- For 346 series: .040"+.003" finished plated through-hole. Using MM #4612 & #4613 pins. See page 162 for details. Patent No. 4,799,904
- Hi-Rel, 4-finger BeCu #30 contact is rated at 3 amps. See page 253 for details
- Insulators are high temperature thermoplastic



ORDERING INFORMATION

FIG. 1	Series 304...770 Solderless Press-Fit																											
	For .062" Thick Boards 304-XX-1__-41-770000 Specify number of pins \uparrow 01-64																											
FIG. 2	Series 304...780 Solderless Press-Fit																											
	For .125" Thick Boards 304-XX-1__-41-780000 Specify number of pins \uparrow 01-64																											
Mill-Max recommends plating Code 13 for Series 304...770 and 304...780																												
FIG. 3	Series 346...012 Compliant Solderless Press-Fit																											
	For .060"-.100" Thick Boards 346-XX-1__-41-012000 Specify number of pins \uparrow 01-64																											
FIG. 4	Series 346...013 Compliant Solderless Press-Fit																											
	For .090"-.130" Thick Boards 346-XX-1__-41-013000 Specify number of pins \uparrow 01-64																											
<div style="display: flex; justify-content: space-around; align-items: center;"> <div style="border: 1px solid black; padding: 5px; background-color: #90EE90;">RoHS-2 2011/65/EU</div> <div style="border: 1px solid black; border-radius: 50%; padding: 5px;">XX=Plating Code See Below</div> <div style="border: 1px solid black; border-radius: 50%; padding: 5px;">For Electrical, Mechanical & Environmental Data, See page 264</div> </div>																												
<table border="1" style="width: 100%; border-collapse: collapse;"> <thead> <tr> <th style="text-align: left;">SPECIFY PLATING CODE XX=</th> <th>11 \blacklozenge</th> <th>13 \blacklozenge</th> <th>91</th> <th>93</th> <th>99</th> <th>41 \blacklozenge</th> <th>43 \blacklozenge</th> <th>44 \blacklozenge</th> </tr> </thead> <tbody> <tr> <td>Sleeve (Pin) </td> <td>10 μ" Au</td> <td>10 μ" Au</td> <td>200 μ" Sn/Pb</td> <td>200 μ" Sn/Pb</td> <td>200 μ" Sn/Pb</td> <td>200 μ" Sn</td> <td>200 μ" Sn</td> <td>200 μ" Sn</td> </tr> <tr> <td>Contact (Clip) </td> <td>10 μ" Au</td> <td>30 μ" Au</td> <td>10 μ" Au</td> <td>30 μ" Au</td> <td>100 μ" Sn/Pb</td> <td>10 μ" Au</td> <td>30 μ" Au</td> <td>100 μ" Sn</td> </tr> </tbody> </table>		SPECIFY PLATING CODE XX=	11 \blacklozenge	13 \blacklozenge	91	93	99	41 \blacklozenge	43 \blacklozenge	44 \blacklozenge	Sleeve (Pin)	10 μ " Au	10 μ " Au	200 μ " Sn/Pb	200 μ " Sn/Pb	200 μ " Sn/Pb	200 μ " Sn	200 μ " Sn	200 μ " Sn	Contact (Clip)	10 μ " Au	30 μ " Au	10 μ " Au	30 μ " Au	100 μ " Sn/Pb	10 μ " Au	30 μ " Au	100 μ " Sn
SPECIFY PLATING CODE XX=	11 \blacklozenge	13 \blacklozenge	91	93	99	41 \blacklozenge	43 \blacklozenge	44 \blacklozenge																				
Sleeve (Pin)	10 μ " Au	10 μ " Au	200 μ " Sn/Pb	200 μ " Sn/Pb	200 μ " Sn/Pb	200 μ " Sn	200 μ " Sn	200 μ " Sn																				
Contact (Clip)	10 μ " Au	30 μ " Au	10 μ " Au	30 μ " Au	100 μ " Sn/Pb	10 μ " Au	30 μ " Au	100 μ " Sn																				



INTERCONNECTS

SERIES 446 • .100" GRID COMPLIANT TAIL • DOUBLE ROW STRIPS

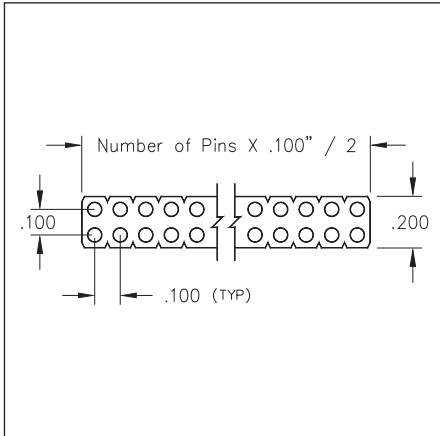

- Compliant tail solderless press-fit: MM #4612 or #4613 pins. Use series 446...012 for .060"-.120" thick boards and series 446...013 for .090"-.130" thick boards. See page 162 for details
- Compliant tail receptacles can be inserted and removed without any degradation of the plated through-hole
- Hi-Rel, 4-finger BeCu #30 contact is rated at 3 amps. See page 253 for details
- Insulators are high temperature thermoplastic

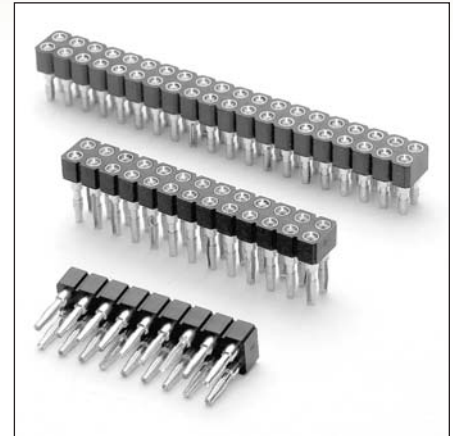

APPLICATION OF COMPLIANT TAIL PINS

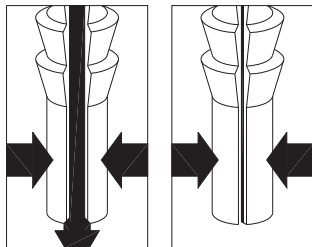

Mill-Max's patented* compliant tail features precision-machined pins that are hollow and slotted to conform to a $.040" \pm .003"$ diameter PTH. As the pin is inserted, the slot compresses to fit the PTH, thus avoiding damage (see illustration at left). The pin's tail has fine serrations that form a perfect "gas tight" connection that doesn't require soldering. And since the pin doesn't damage the hole, compliant tail sockets and connectors can be easily replaced.

*Patent No. 4,799,904.

ORDERING INFORMATION

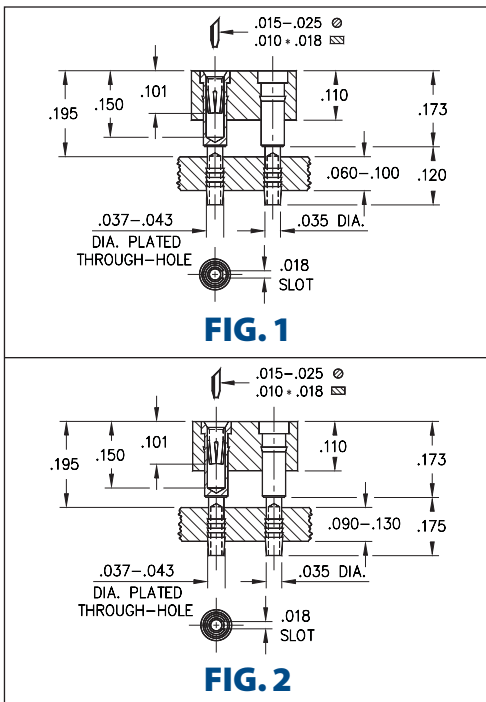

FIG. 1	Series 446...012	Compliant Tail Socket
	446-XX-2	-41-012000
FIG. 2	Series 446...013	Compliant Tail Socket
	446-XX-2	-41-013000



XX=Plating Code
See Below

For
Electrical, Mechanical
& Environmental Data,
See page 264

SPECIFY PLATING CODE XX=	13	93	99	43	44
Sleeve (Pin)	10 μ " Au	200 μ " Sn/Pb	200 μ " Sn/Pb	200 μ " Sn	200 μ " Sn
Contact (Clip)	30 μ " Au	30 μ " Au	100 μ " Sn/Pb	30 μ " Au	100 μ " Sn



INTERCONNECTS

SERIES 712 • .100" GRID CARRIER WITH SOLDER TAIL • SINGLE AND DOUBLE ROW STRIPS

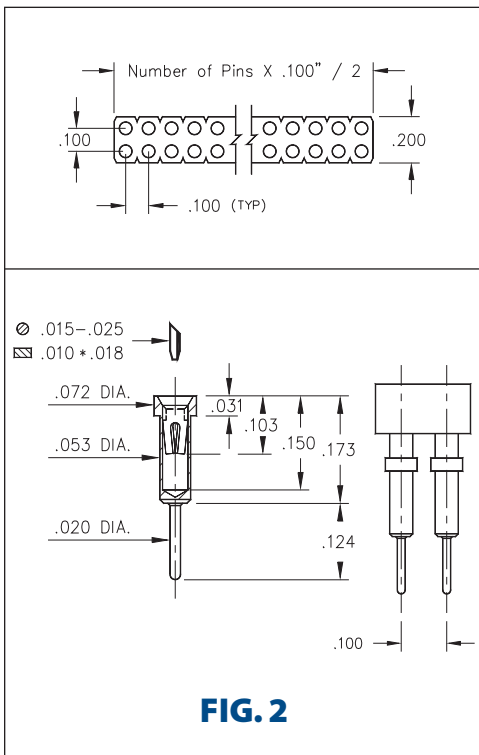
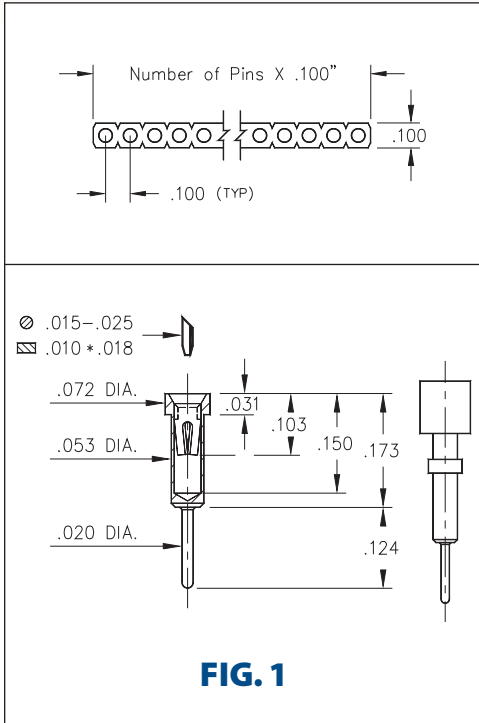

- Standard solder tail receptacles can be mounted as a low profile receptacle or by the solder tail for use in smaller diameter holes
- Series 712 use MM #0255 pins. See page 165 for details
- Hi-Rel, 4-finger BeCu #30 contact is rated at 3 amps. See page 253 for details
- Insulators are high temperature thermoplastic, suitable for all soldering operations



ORDERING INFORMATION

FIG. 1	Single Row (.028" or .055" min. mounting holes)
	712-XX-1--41-001000 Specify number of pins 01-64
FIG. 2	Double Row (.028" or .055" min. mounting holes)
	712-XX-2--41-001000 Specify number of pins 04-64



XX=Plating Code
See Below

For
Electrical, Mechanical
& Environmental Data,
See page 264

SPECIFY PLATING CODE XX=	11	13	91	93	41	43
Sleeve (Pin)	10 μ" Au	10 μ" Au	200 μ" Sn/Pb	200 μ" Sn/Pb	200 μ" Sn	200 μ" Sn
Contact (Clip)	10 μ" Au	30 μ" Au	10 μ" Au	30 μ" Au	10 μ" Au	30 μ" Au



INTERCONNECTS

SERIES 714...00X • .100" GRID LOW PROFILE CARRIERS • SINGLE AND DOUBLE ROW STRIPS

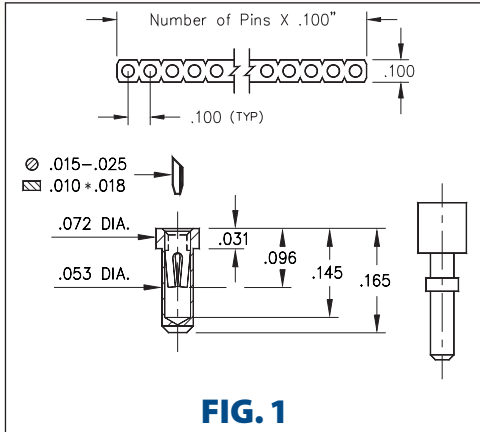

FIG. 1

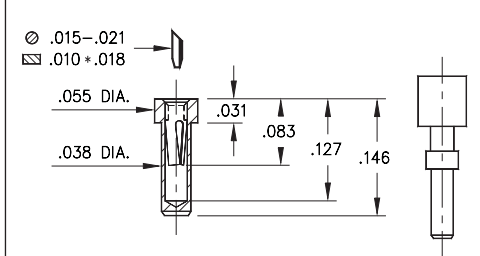

FIG. 2

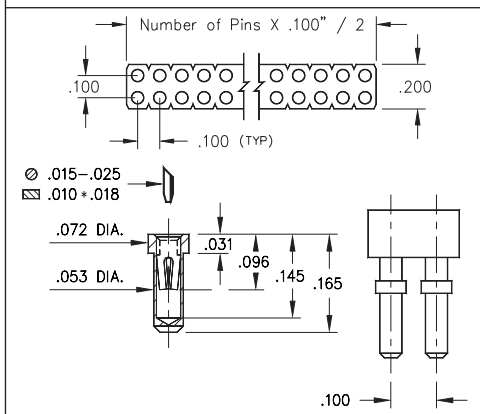

FIG. 3

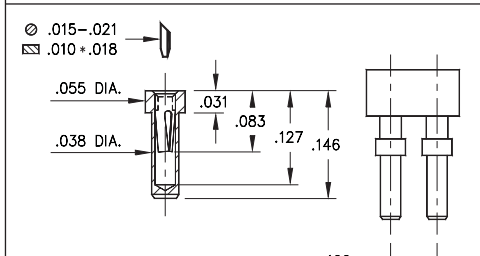
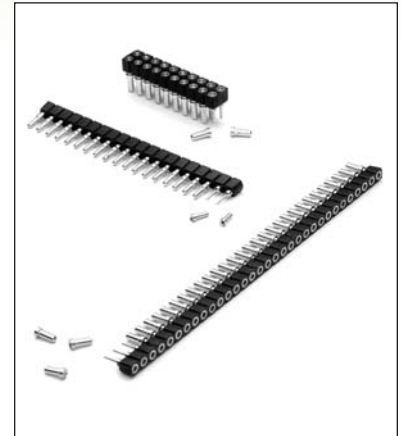

FIG. 4

- Low profile receptacles sit .031" above the board
- Series 714 use MM #1401 and MM #1407 pin receptacles. See pages 157 and 170 for details
- Hi-Rel, 4-finger BeCu #30 contact is used in the #1401 receptacle and a BeCu #11 contact is used in the #1407. Both contacts are rated at 3 amps. See pages 251 and 253 for details
- Insulators are high temperature thermoplastic, suitable for all soldering operations



ORDERING INFORMATION

	Single Row (.055" min. mounting hole)
FIG. 1	714-XX-1__-41-001000 Specify number of pins 01-64
	Single Row (.039" min. mounting hole)
FIG. 2	714-XX-1__-31-007000 Specify number of pins 01-64
	Double Row (.055" min. mounting hole)
FIG. 3	714-XX-2__-41-001000 Specify number of pins 04-64
	Double Row (.039" min. mounting hole)
FIG. 4	714-XX-2__-31-007000 Specify number of pins 04-64



XX=Plating Code
See Below

For
Electrical, Mechanical
& Environmental Data,
See page 264

SPECIFY PLATING CODE XX=	91	93	41	43
Sleeve (Pin)	200 μ"Sn/Pb	200 μ"Sn/Pb	200 μ"Sn	200 μ"Sn
Contact (Clip)	10 μ"Au	30 μ"Au	10 μ"Au	30 μ"Au



INTERCONNECTS

SERIES 714...01X • .100" GRID ULTRA LOW PROFILE CARRIERS • SINGLE AND DOUBLE ROW STRIPS

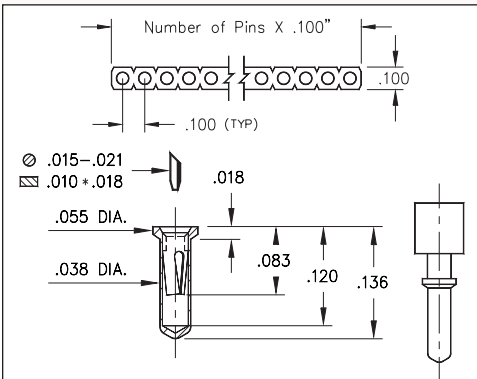

FIG. 1

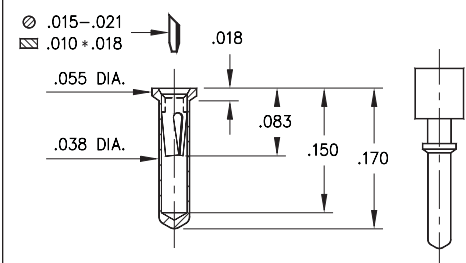

FIG. 2

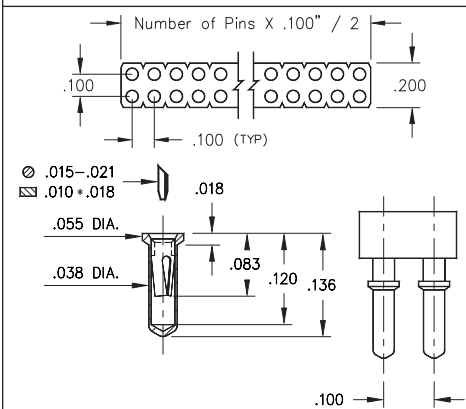

FIG. 3

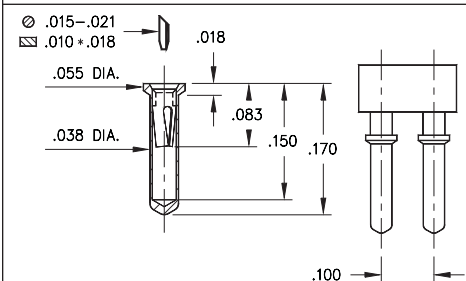
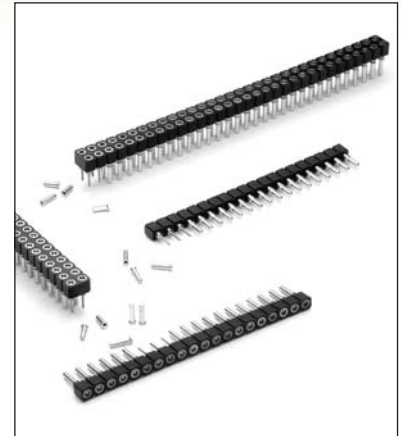

FIG. 4

- Ultra low profile receptacles sit .018" above the board
- Series 714 use MM #0552-1 and MM #0552-2 pin receptacles. See page 158 for details
- Hi-Rel, 3-finger BeCu #11 contact is rated at 3 amps. See page 251 for details
- Insulators are high temperature thermoplastic, suitable for all soldering operations



ORDERING INFORMATION

FIG. 1	Single Row (.039" min. mounting hole)	714-XX-1__-31-012000
	Specify number of pins	01-64
FIG. 2	Single Row (.039" min. mounting hole)	714-XX-1__-31-018000
	Specify number of pins	01-64
FIG. 3	Double Row (.039" min. mounting hole)	714-XX-2__-31-012000
	Specify number of pins	04-64
FIG. 4	Double Row (.039" min. mounting hole)	714-XX-2__-31-018000
	Specify number of pins	04-64



XX=Plating Code
See Below

For
Electrical, Mechanical
& Environmental Data,
See page 264

SPECIFY PLATING CODE XX=	91	93	41	43
Sleeve (Pin)	200 μ"Sn/Pb	200 μ"Sn/Pb	200 μ"Sn	200 μ"Sn
Contact (Clip)	10 μ" Au	30 μ" Au	10 μ" Au	30 μ" Au



INTERCONNECTS

SERIES 335, 364, 435, 464 • .100" GRID (.018" DIA. PINS), LOW PROFILE • SINGLE AND DOUBLE ROW STRIPS

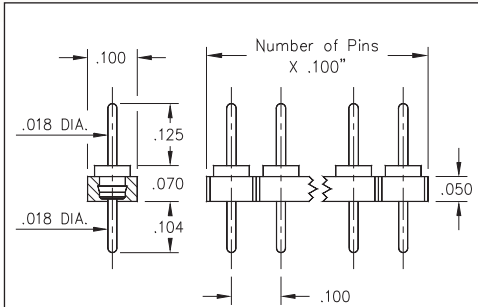

FIG. 1

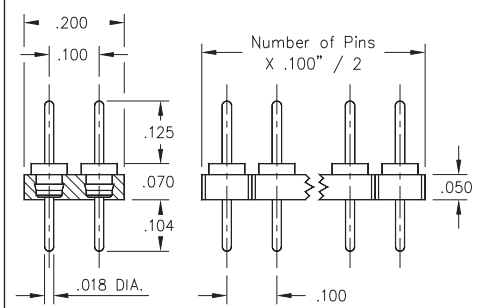

FIG. 2

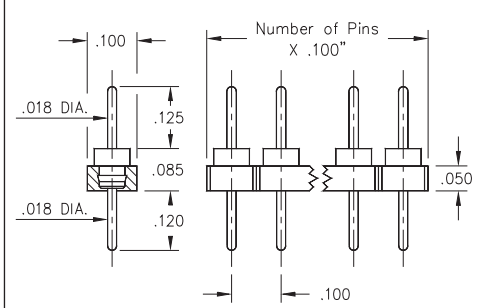

FIG. 3

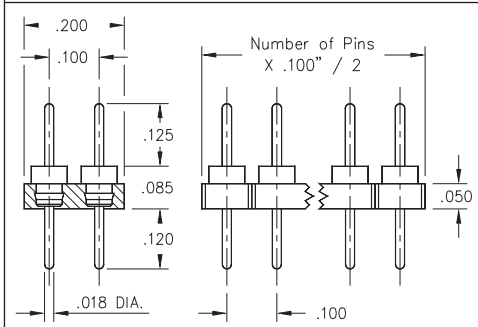

FIG. 4

- Series 335 and 435 single and double row PCB interconnects offer a .070" profile, the lowest available
- Series 364 and 464 single and double row PCB interconnects offer .085" profile above board
- Series 335 and 435 use MM #3516 pins. See page 212 for details
- Series 364 and 464 use MM #6458 pins. See page 213 for details
- Insulators are high temperature thermoplastic, suitable for all soldering operations



ORDERING INFORMATION

FIG. 1	Series 335...160 Single Row .070" Profile Pin Header
	335-XX-1__-00-160000 Specify number of pins 01-32
FIG. 2	Series 435...160 Double Row .070" Profile Pin Header
	435-XX-2__-00-160000 Specify number of pins 04-72
FIG. 3	Series 364...580 Single Row .085" Profile Pin Header
	364-10-1__-00-580000 Specify number of pins 01-32
FIG. 4	Series 464...580 Double Row .085" Profile Pin Header
	464-10-2__-00-580000 Specify number of pins 04-72
<div style="display: flex; justify-content: space-around; align-items: center;"> <div style="border: 1px solid black; padding: 5px; background-color: #90EE90;">RoHS - 2 2011/65/EU</div> <div style="border: 1px solid black; border-radius: 50%; padding: 5px;">XX=Plating Code See Below</div> <div style="border: 1px solid black; border-radius: 50%; padding: 5px;">For Electrical, Mechanical & Environmental Data, See page 264</div> </div>	
SPECIFY PLATING CODE XX=	10 ◆ 90 40 ◆
Pin Plating	10 μ" Au 200 μ" Sn/Pb 200 μ" Sn

INTERCONNECTS

SERIES 351 • .100" GRID INTERCONNECT HEADERS • SINGLE ROW STRIPS

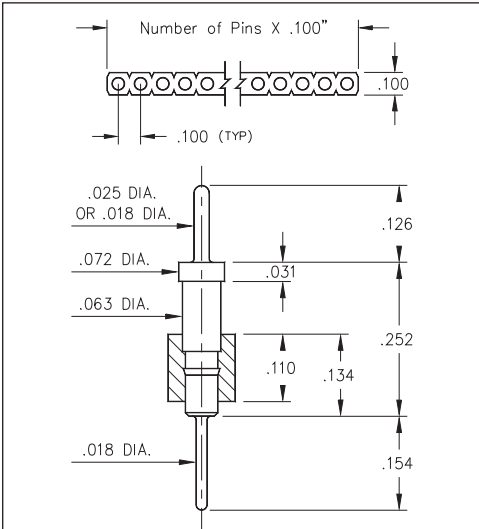

FIG. 1

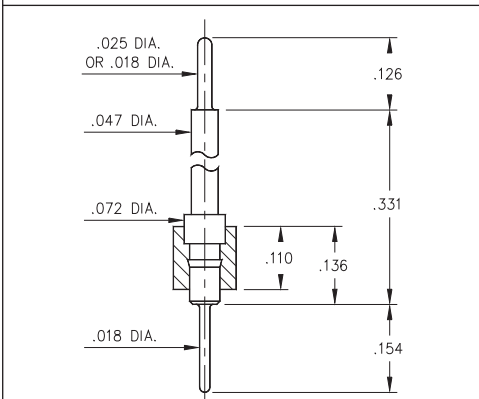

FIG. 2

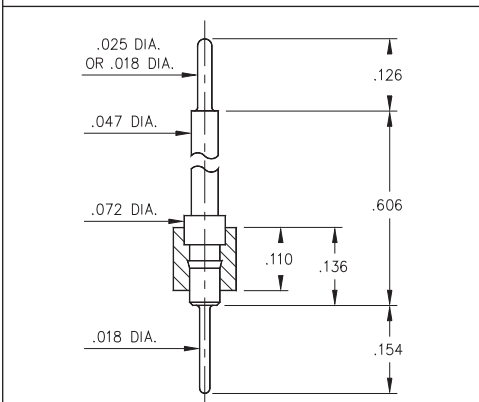

FIG. 3

- Series 351 interconnect header strips come in three lengths with .018" dia. pluggable solder tails at one end and .025" dia. pins at the other. Please see series:
351...003 uses pin #5503
351...004 uses pin #5504
351...005 uses pin #5505
- .018" pluggable solder tails are available at both ends. Please see series:
351...009 uses pin #5509
351...010 uses pin #5510
351...011 uses pin #5511
See pages 212 and 214 for details
- Insulators are high temperature thermoplastic, suitable for all soldering operations



ORDERING INFORMATION

FIG. 1	Series 351...003 .018" / .025" Dia. Solder Tails
	351-10-1__-00-003000 Specify number of pins 01-64
FIG. 2	Series 351...009 .018" / .018" Dia. Solder Tails
	351-10-1__-00-009000 Specify number of pins 01-64
FIG. 2	Series 351...004 .018" / .025" Dia. Solder Tails
	351-10-1__-00-004000 Specify number of pins 01-64
FIG. 3	Series 351...010 .018" / .018" Dia. Solder Tails
	351-10-1__-00-010000 Specify number of pins 01-64
FIG. 3	Series 351...005 .018" / .025" Dia. Solder Tails
	351-10-1__-00-005000 Specify number of pins 01-64
FIG. 3	Series 351...011 .018" / .018" Dia. Solder Tails
	351-10-1__-00-011000 Specify number of pins 01-64



XX=Plating Code
See Below

For
Electrical, Mechanical
& Environmental Data,
See page 264

SPECIFY PLATING CODE XX=	10 ◆			
Pin Plating	10 μ" Au			



INTERCONNECTS

SERIES 451 • .100" GRID INTERCONNECT HEADERS • DOUBLE ROW STRIPS

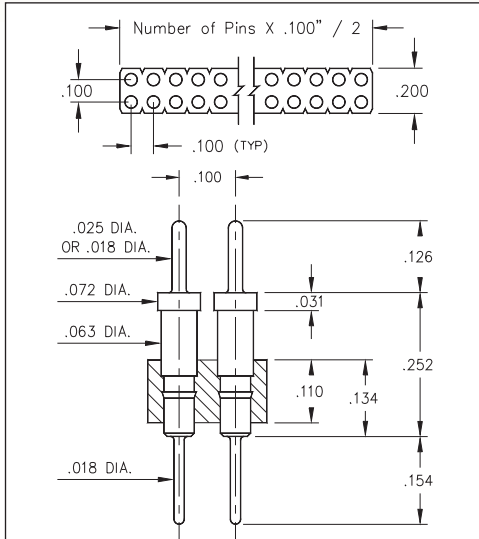

FIG. 1

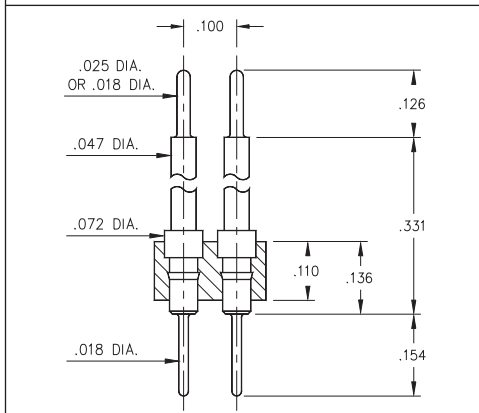

FIG. 2

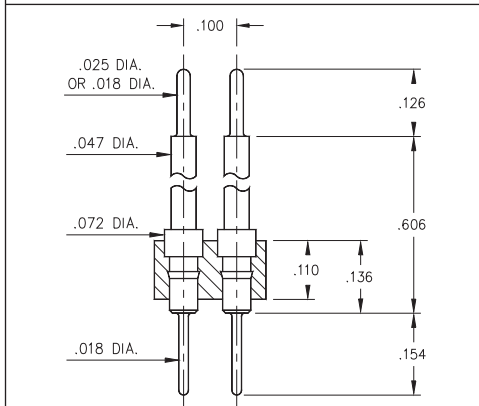

FIG. 3

- Series 451 interconnect header strips come in three lengths with .018" dia. pluggable solder tails at one end and .025" dia. pins at the other. Please see series:
451...003 uses pin #5503
451...004 uses pin #5504
451...005 uses pin #5505
- .018" pluggable solder tails are available at both ends. Please see series:
451...009 uses pin #5509
451...010 uses pin #5510
451...011 uses pin #5511
See pages 212 and 214 for details
- Insulators are high temperature thermoplastic, suitable for all soldering operations



ORDERING INFORMATION

FIG. 1	Series 451...003 .018" / .025" Dia. Solder Tails
	451-10-2-__-00-003000 Specify number of pins 04-64
FIG. 2	Series 451...009 .018" / .018" Dia. Solder Tails
	451-10-2-__-00-009000 Specify number of pins 04-64
FIG. 2	Series 451...004 .018" / .025" Dia. Solder Tails
	451-10-2-__-00-004000 Specify number of pins 04-64
FIG. 3	Series 451...010 .018" / .018" Dia. Solder Tails
	451-10-2-__-00-010000 Specify number of pins 04-64
FIG. 3	Series 451...005 .018" / .025" Dia. Solder Tails
	451-10-2-__-00-005000 Specify number of pins 04-64
FIG. 3	Series 451...011 .018" / .018" Dia. Solder Tails
	451-10-2-__-00-011000 Specify number of pins 04-64



XX=Plating Code
See Below

For
Electrical, Mechanical
& Environmental Data,
See page 264

SPECIFY PLATING CODE XX=	10			
Pin Plating	10 μ Au			



INTERCONNECTS

SERIES 334 • .100" GRID INTERCONNECT HEADERS • SINGLE ROW STRIPS

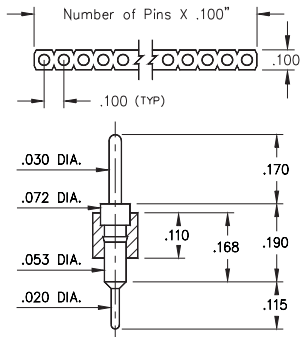

FIG. 1

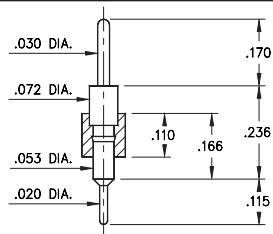

FIG. 2

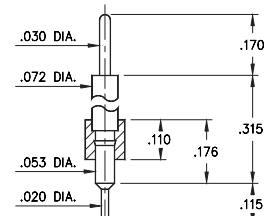

FIG. 3

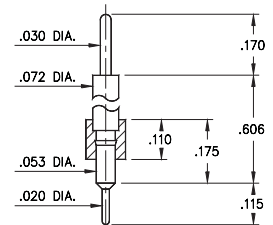

FIG. 4

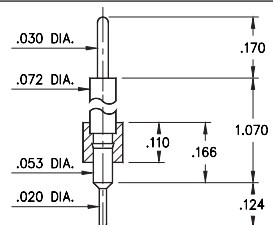

FIG. 5

• Series 334 interconnect header strips are available in 5 lengths:

- 334...020 uses pin #3402 (L = .190")
 - 334...010 uses pin #3401 (L = .236")
 - 334...050 uses pin #3405 (L = .315")
 - 334...000 uses pin #3400 (L = .606")
 - 334...100 uses pin #3410 (L = 1.070")
- See page 215 for details

• Strips come with .020" pluggable soldertails at one end and .030" tails at the other

• Insulators are high temperature thermoplastic, suitable for all soldering operations



ORDERING INFORMATION

FIG. 1	Series 334...020	.020" / .030" Dia. Solder Tails								
	334-XX-1	-00-020000 ↑ Specify number of pins 01-64								
FIG. 2	Series 334...010	.020" / .030" Dia. Solder Tails								
	334-XX-1	-00-010000 ↑ Specify number of pins 01-64								
FIG. 3	Series 334...050	.020" / .030" Dia. Solder Tails								
	334-XX-1	-00-050000 ↑ Specify number of pins 01-64								
FIG. 4	Series 334...000	.020" / .030" Dia. Solder Tails								
	334-XX-1	-00-000000 ↑ Specify number of pins 01-64								
FIG. 5	Series 334...100	.020" / .030" Dia. Solder Tails								
	334-XX-1	-00-100000 ↑ Specify number of pins 01-64								
<div style="display: flex; justify-content: space-around; align-items: center;"> <div style="border: 1px solid black; padding: 5px; background-color: #90EE90;">RoHS - 2 2011/65/EU</div> <div style="border: 1px solid black; border-radius: 50%; padding: 5px;">XX=Plating Code See Below</div> <div style="border: 1px solid black; border-radius: 50%; padding: 5px;">For Electrical, Mechanical & Environmental Data, See page 264</div> </div>										
<table border="1" style="width: 100%; border-collapse: collapse;"> <thead> <tr> <th style="width: 25%;">SPECIFY PLATING CODE XX=</th> <th style="width: 25%;">10 ◆</th> <th style="width: 25%;">90</th> <th style="width: 25%;">40 ◆</th> </tr> </thead> <tbody> <tr> <td>Pin Plating </td> <td>10 μ" Au</td> <td>200 μ" Sn/Pb</td> <td>200 μ" Sn</td> </tr> </tbody> </table>			SPECIFY PLATING CODE XX=	10 ◆	90	40 ◆	Pin Plating	10 μ" Au	200 μ" Sn/Pb	200 μ" Sn
SPECIFY PLATING CODE XX=	10 ◆	90	40 ◆							
Pin Plating	10 μ" Au	200 μ" Sn/Pb	200 μ" Sn							



INTERCONNECTS

SERIES 342 • .100" GRID BOARD STACKING HEADERS • SINGLE ROW STRIPS

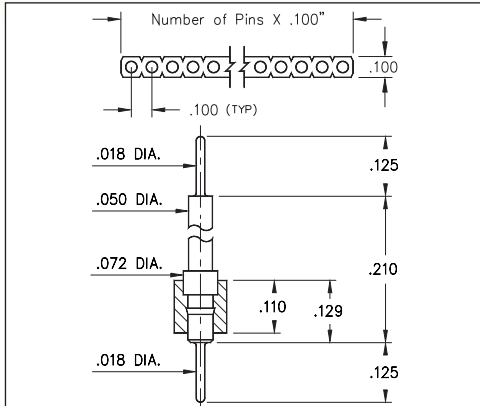

FIG. 1

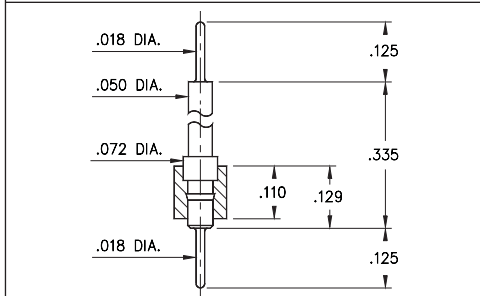

FIG. 2

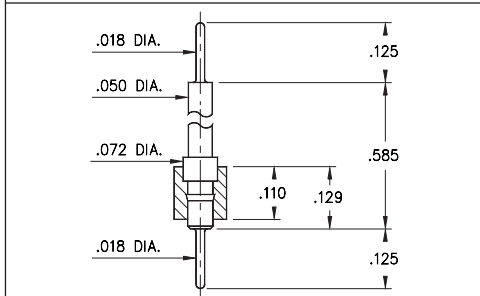

FIG. 3

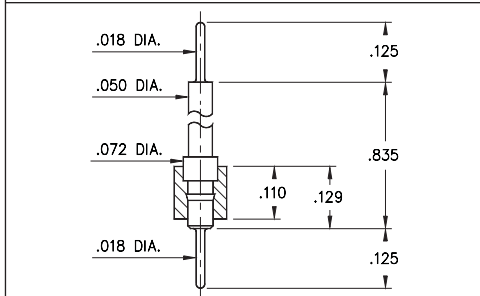

FIG. 4

- Series 342 interconnect header strips come in four heights with .018" dia. pluggable solder tails at both ends

342...591 uses pin #4259-1 (L = .210")
 342...592 uses pin #4259-2 (L = .335")
 342...593 uses pin #4259-3 (L = .585")
 342...594 uses pin #4259-4 (L = .835")
 See page 212 for details

- Insulators are high temperature thermoplastic, suitable for all soldering operations



ORDERING INFORMATION

	Series 342...591	.018" / .018" Dia. Solder Tails
FIG. 1	342-XX-1	-00-591000
	Specify number of pins	01-64
FIG. 2	Series 342...592	.018" / .018" Dia. Solder Tails
	342-XX-1	-00-592000
	Specify number of pins	01-64
FIG. 3	Series 342...593	.018" / .018" Dia. Solder Tails
	342-XX-1	-00-593000
	Specify number of pins	01-64
FIG. 4	Series 342...594	.018" / .018" Dia. Solder Tails
	342-XX-1	-00-594000
	Specify number of pins	01-64



XX=Plating Code
See Below

For
Electrical, Mechanical
& Environmental Data,
See page 264

SPECIFY PLATING CODE XX=	10 ◆	90	40 ◆	
Pin Plating	10 μ" Au	200 μ" Sn/Pb	200 μ" Sn	



INTERCONNECTS

SERIES 442 • .100" GRID BOARD STACKING HEADERS • DOUBLE ROW STRIPS

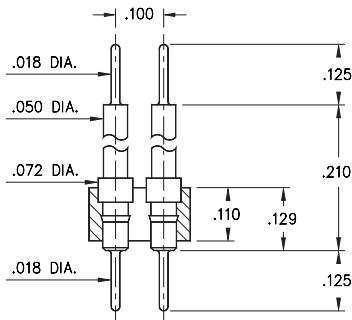

FIG. 1

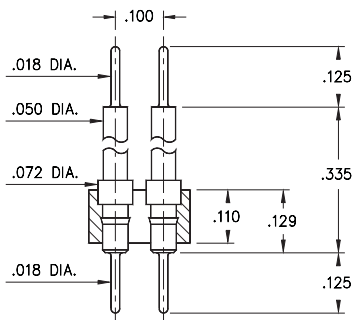

FIG. 2

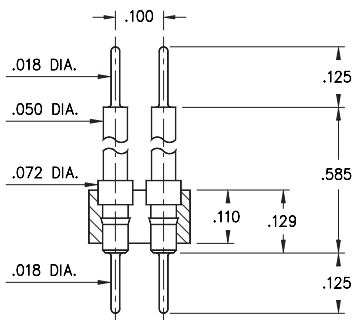

FIG. 3

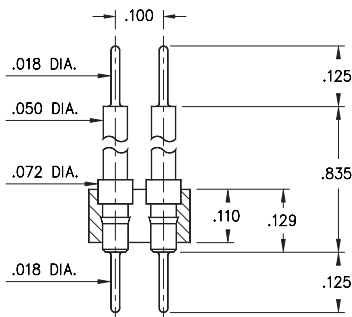
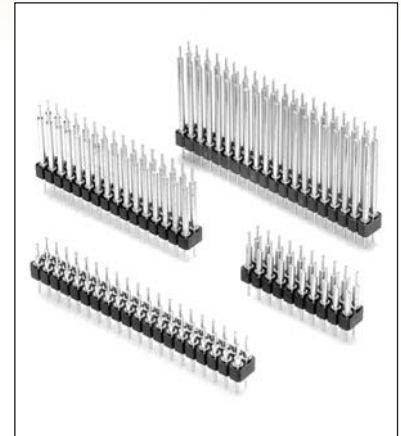

FIG. 4

- Series 442 interconnect header strips come in four heights with .018" dia. pluggable solder tails at both ends

442...591 uses pin #4259-1 (L = .210")
 442...592 uses pin #4259-2 (L = .335")
 442...593 uses pin #4259-3 (L = .585")
 442...594 uses pin #4259-4 (L = .835")
 See page 212 for details

- Insulators are high temperature thermoplastic, suitable for all soldering operations



ORDERING INFORMATION

FIG. 1	Series 442...591 .018" / .018" Dia. Solder Tails
	442-XX-2--00-591000 Specify number of pins 04-64
FIG. 2	Series 442...592 .018" / .018" Dia. Solder Tails
	442-XX-2--00-592000 Specify number of pins 04-64
FIG. 3	Series 442...593 .018" / .018" Dia. Solder Tails
	442-XX-2--00-593000 Specify number of pins 04-64
FIG. 4	Series 442...594 .018" / .018" Dia. Solder Tails
	442-XX-2--00-594000 Specify number of pins 04-64



XX=Plating Code
See Below

For
Electrical, Mechanical
& Environmental Data,
See page 264

SPECIFY PLATING CODE XX=	10 ◆	90	40 ◆	
Pin Plating	10 μ" Au	200 μ" Sn/Pb	200 μ" Sn	



INTERCONNECTS

SERIES 350, 360, 370, 380 • .100" GRID SOLDER TAIL • SINGLE ROW STRIPS

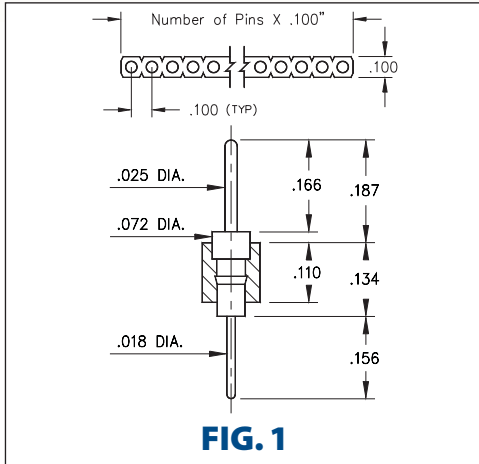

FIG. 1

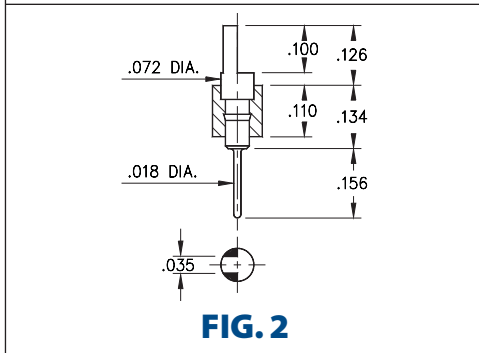

FIG. 2

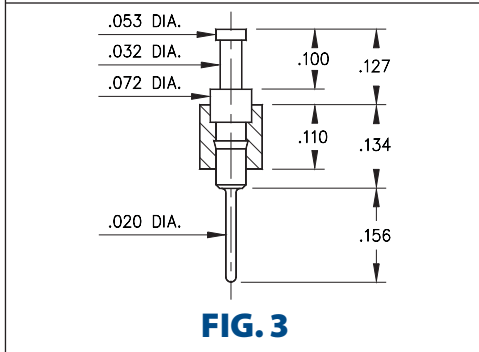

FIG. 3

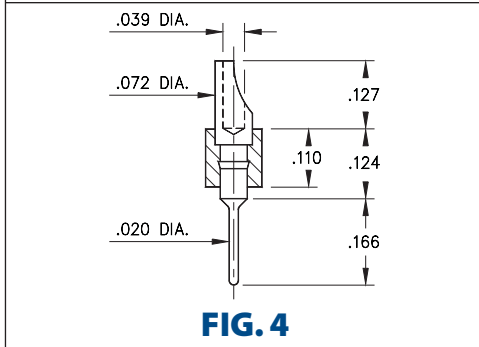

FIG. 4

- Series 350, 360, 370 & 380 single row header strips come in various styles (pin, slotted, head, turret and solder cup) with pluggable solder tails

350...001 uses pin #0290

360...001 uses pin #0282

370...001 uses pin #0700

380...001 uses pin #8000

See pages 215 and 216 for details

- Insulators are high temperature thermoplastic, suitable for all soldering operations



ORDERING INFORMATION

	Series 350...001	.025" / .018" Dia. Solder Tails		
FIG. 1	350-XX-1	-00-001000	Specify number of pins 01-64	
FIG. 2	Series 360...001	Slotted Head / Solder Tail		
	360-XX-1	-00-001000	Specify number of pins 01-64	
FIG. 3	Series 370...001	Turret / Solder Tail		
	370-XX-1	-00-001000	Specify number of pins 01-64	
FIG. 4	Series 380...001	Solder Cup / Solder Tail		
	380-XX-1	-00-001000	Specify number of pins 01-64	
<div style="display: flex; justify-content: space-around; align-items: center;"> <div style="border: 1px solid black; padding: 5px; background-color: #90EE90;">RoHS - 2 2011/65/EU</div> <div style="border: 1px solid black; border-radius: 50%; padding: 5px;">XX=Plating Code See Below</div> <div style="border: 1px solid black; border-radius: 50%; padding: 5px;">For Electrical, Mechanical & Environmental Data, See page 264</div> </div>				
SPECIFY PLATING CODE XX=		10 ◆	90	40 ◆
Pin Plating		10 μ" Au	200 μ" Sn/Pb	200 μ" Sn



INTERCONNECTS

SERIES 450, 460, 470, 480 • .100" GRID SOLDER TAIL • DOUBLE ROW STRIPS

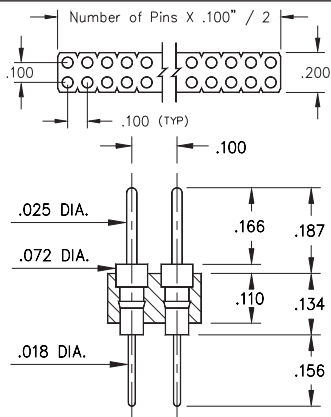

FIG. 1

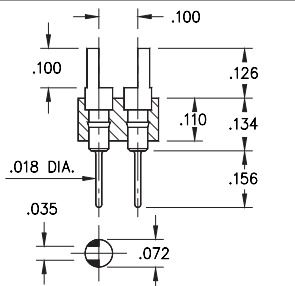

FIG. 2

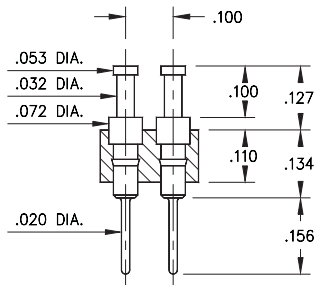

FIG. 3

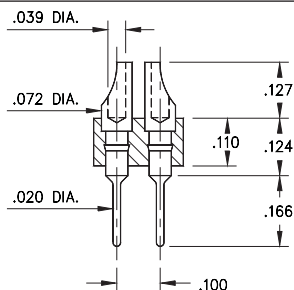

FIG. 4

- Series 450, 460, 470 & 480 double row header strips come in various styles (pin, slotted, head, turret and solder cup) with pluggable solder tails

450...001 uses pin #0290

460...001 uses pin #0282

470...001 uses pin #0700

480...001 uses pin #8000

See pages 215 and 216 for details

- Insulators are high temperature thermoplastic, suitable for all soldering operations

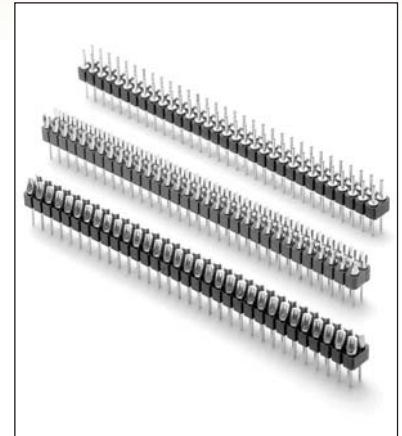

ORDERING INFORMATION

	Series 450...001	.025" / .018" Dia. Solder Tails
FIG. 1	450-XX-2	-00-001000
	Specify number of pins	04-64
FIG. 2	Series 460...001	Slotted Head / Solder Tail
	460-10-2	-00-001000
	Specify number of pins	02-64
FIG. 3	Series 470...001	Turret / Solder Tail
	470-XX-2	-00-001000
	Specify number of pins	04-64
FIG. 4	Series 480...001	Solder Cup / Solder Tail
	480-10-2	-00-001000
	Specify number of pins	02-64



XX=Plating Code
See Below

For
Electrical, Mechanical
& Environmental Data,
See page 264

SPECIFY PLATING CODE XX=	10	90	40	
Pin Plating	10 μ" Au	200 μ" Sn/Pb	200 μ" Sn	



INTERCONNECTS

SERIES 353, 362, 363, 373, 382, 383 • .100" GRID WRAPOST • SINGLE ROW STRIPS

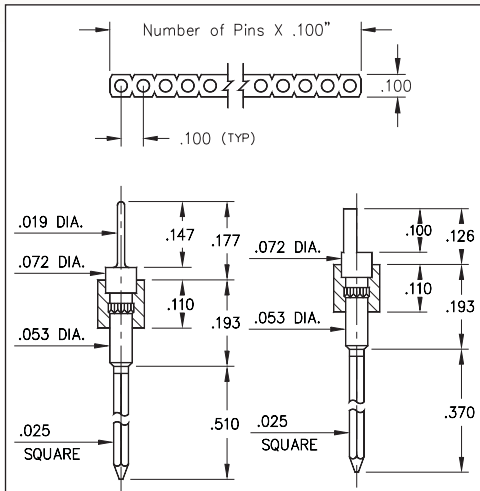

FIG. 1

FIG. 2

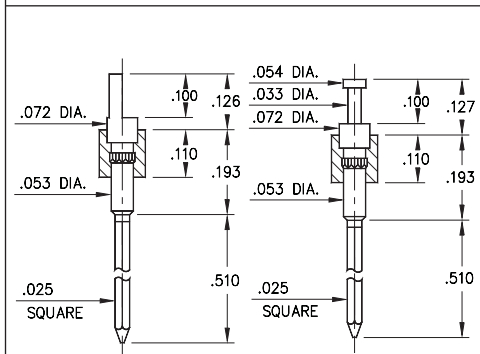

FIG. 3

FIG. 4

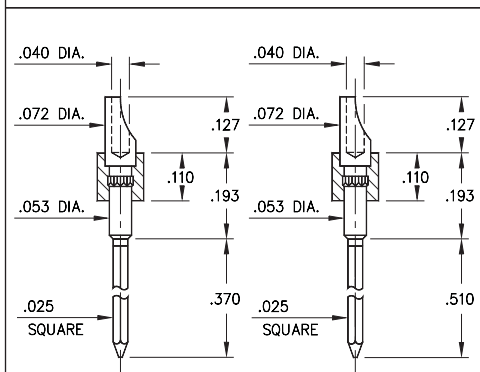

FIG. 5

FIG. 6

- Series 353, 362, 363, 373, 382 and 383 single row header strips come in various styles (pin, slotted head, turret and solder cup) with wrapost tails

- 353...001 uses pin #5301
- 362...001 uses pin #1106-2
- 363...001 uses pin #1106-3
- 373...001 uses pin #0730-3
- 382...001 uses pin #8301-2
- 383...001 uses pin #8301-3

- See pages 227 and 228 for details
- Insulators are high temperature thermoplastic, suitable for all soldering operations

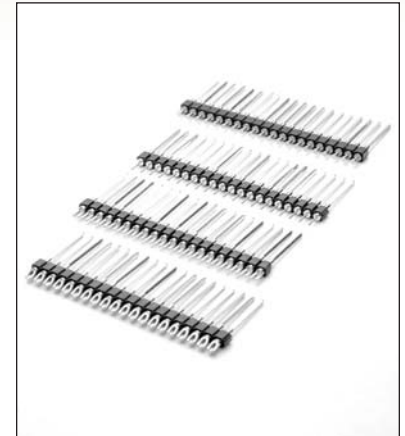

ORDERING INFORMATION

	Series 353...001	Pin / 3 Level Wrapost
FIG. 1	353-XX-1	-00-001000 Specify number of pins 01-64
FIG. 2	Series 362...001	Slotted Head / 2 Level Wrapost
FIG. 3	362-XX-1	-00-001000 Specify number of pins 01-64
FIG. 4	Series 363...001	Slotted Head / 3 Level Wrapost
FIG. 5	363-XX-1	-00-001000 Specify number of pins 01-64
FIG. 6	Series 373...001	Turret / 3 Level Wrapost
FIG. 7	373-XX-1	-00-001000 Specify number of pins 01-64
FIG. 8	Series 382...001	Solder Cup / 2 Level Wrapost
FIG. 9	382-XX-1	-00-001000 Specify number of pins 01-64
FIG. 10	Series 383...001	Solder Cup / 3 Level Wrapost
FIG. 11	383-XX-1	-00-001000 Specify number of pins 01-64



XX=Plating Code See Below

For Electrical, Mechanical & Environmental Data, See page 264

SPECIFY PLATING CODE XX=	10	90	40
Pin Plating	10 μ" Au	200 μ" Sn/Pb	200 μ" Sn



INTERCONNECTS

SERIES 453, 463, 473, 483 • .100" GRID WRAPOST • DOUBLE ROW STRIPS

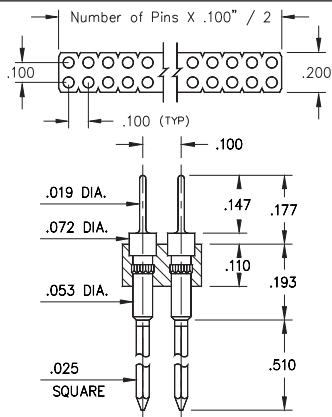

FIG. 1

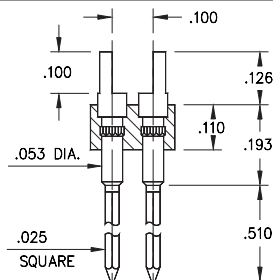

FIG. 2

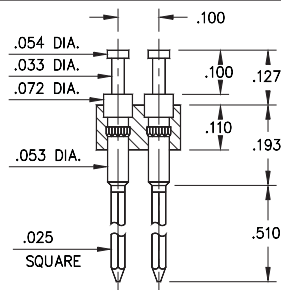

FIG. 3

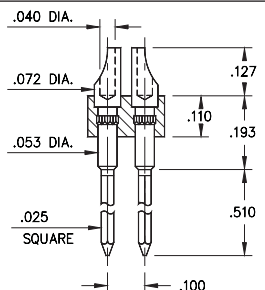

FIG. 4

- Series 453, 463, 473, and 483 double row header strips come in various styles (pin, slotted head, turret and solder cup) with wrapost tails





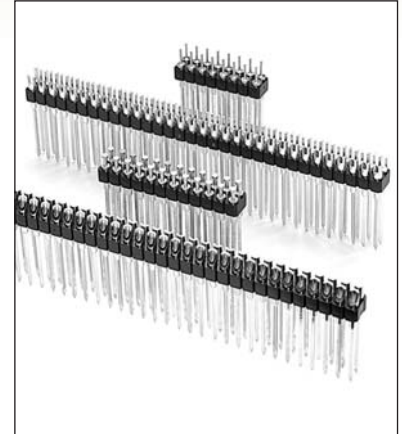

453...001 uses pin #5301
 463...001 uses pin #1106-3
 473...001 uses pin #0730-3
 483...001 uses pin #8301-3

See pages 227 and 228 for details

- Insulators are high temperature thermoplastic, suitable for all soldering operations



ORDERING INFORMATION

	Series 453...001	Pin / 3 Level Wrapost		
FIG. 1	453-10-2	-00-001000 Specify number of pins 04-64		
FIG. 2	Series 463...001	Slotted Head / 3 Level Wrapost		
	463-XX-2	-00-001000 Specify number of pins 02-64		
FIG. 3	Series 473...001	Turret / 3 Level Wrapost		
	473-XX-2	-00-001000 Specify number of pins 04-64		
FIG. 4	Series 483...001	Solder Cup / 3 Level Wrapost		
	483-XX-2	-00-001000 Specify number of pins 02-64		
  				
SPECIFY PLATING CODE XX=	10 	90	40 	
Pin Plating 	10 μ" Au	200 μ" Sn/Pb	200 μ" Sn	

