

# Sidewinder AC Current Sensor

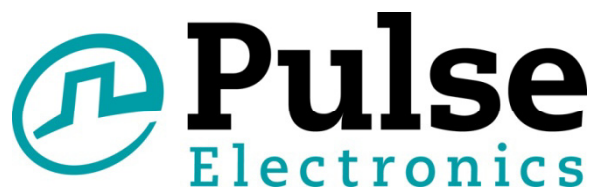

G043.C (4/13)

# Rogowski Coil Fundamentals

- Sidewinder Current Sensor is based on the Rogowski Coil Principle
- When an AC current flows through the center of the sensor, an output voltage is induced, that is proportional to the rate of change of the current,  $di(t)/dt$

$$v(t)_{\text{out}} = -M \dot{i}(t)/dt$$

where  $M = \mu_0 sn$

$\mu_0$  = permeability of air =  $4\pi \cdot 10^{-7}$  H/m

$s$  = cross sectional area of a turn ( $\text{m}^2$ )

$n$  = number of turns per unit length (m)

Discovered by W. Rogowski in 1912

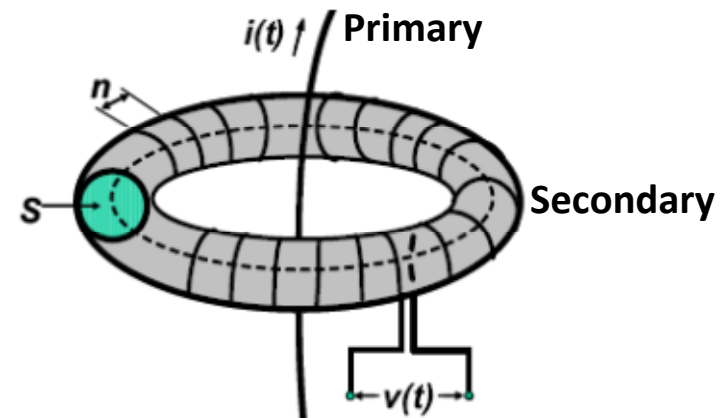

# Current Sensing Focus on Metering

---

- AC current sensor, for 50/60Hz, 120/240V Single Phase applications
- Designed to provide a highly linear output voltage over a very wide dynamic range of 3000:1
- Meets the Class 0.2 percent accuracy limits for currents from 0.1 A to 200A and above for IEC 60044 and ANSI C12.20
- Patent Pending design provides immunity to external magnetic fields
  - Per IEC 62053-21 and 62053-22, Table 6, Class 0.5
  - Per ANSI C12.1 and C12.20, Test 18
- Additional Faraday shield provides immunity to external voltage fields
- Coreless design provides lower cost than a CT
- Very high bandwidth AC Sensor from 1 Hz up to 1MHz and higher
- Suitable for Arc Fault Sensing in high current applications

# Technology Comparison

Characteristic	Shunt	Current Xfmr	Hall Effect	Rogowski Coil
Linear Amplitude & Phase	++	0	-	++
Wide Range – 5 decades	0	0	+	++
High Saturation Current	-	--	-	++
Wide Bandwidth	+	0	0	+
DC Immunity	++	-	-	++
Temperature Independent	-	+	-	++
Low Power Consumption	-	+	0	++
Low Cost	++	0	-	+
Tamper resistant	+	-	0	+
Light Weight	+	-	+	+
Flexible size & shape	0	-	+	++

# Pulse Sidewinder Products

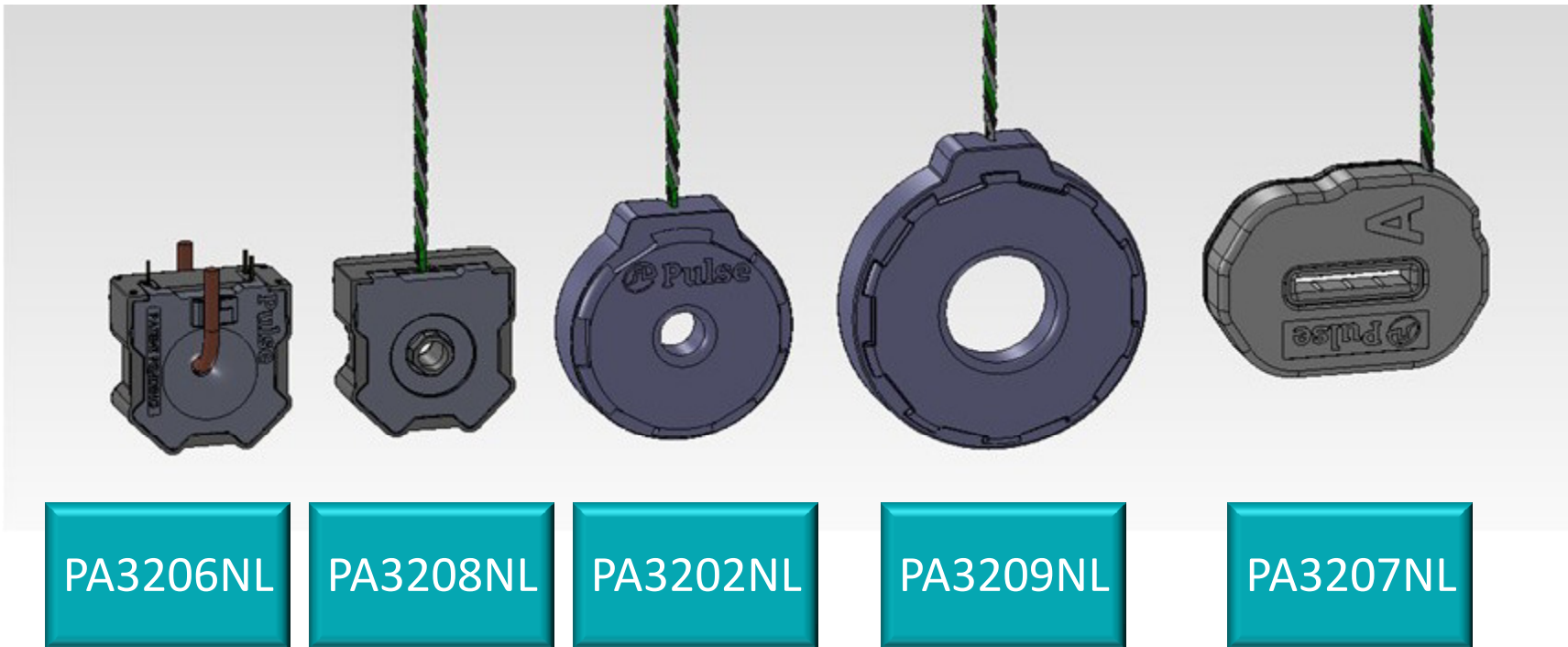

# Pulse Sidewinder Products

Pulse has 5 current sensors in the Sidewinder product family

Part	Accuracy Class	Output Level @ 50Hz	Output Level @ 60Hz	Current Range (see note)
PA3202NL	0.2 %	416 $\mu\text{V/A}$	500 $\mu\text{V/A}$	0.1 A – 200 A
PA3206NL	0.2 %	383 $\mu\text{V/A}$	460 $\mu\text{V/A}$	0.1A – 40 A
<b>New</b> PA3207NL	0.2 %	408 $\mu\text{V/A}$	490 $\mu\text{V/A}$	0.1A – 200 A
PA3208NL	0.2 %	383 $\mu\text{V/A}$	460 $\mu\text{V/A}$	0.1A – 120 A
PA3209NL	0.2 %	463 $\mu\text{V/A}$	556 $\mu\text{V/A}$	0.1 A – 1000 A

Note: The current range is limited by the maximum current of the buss bar through the hole. The Rogowski Coil sensor has no core and cannot saturate, and therefore there is no maximum current for the sensor, only for the buss bar.

# Pulse Current Sensor

## Low Frequency Equivalent Circuit

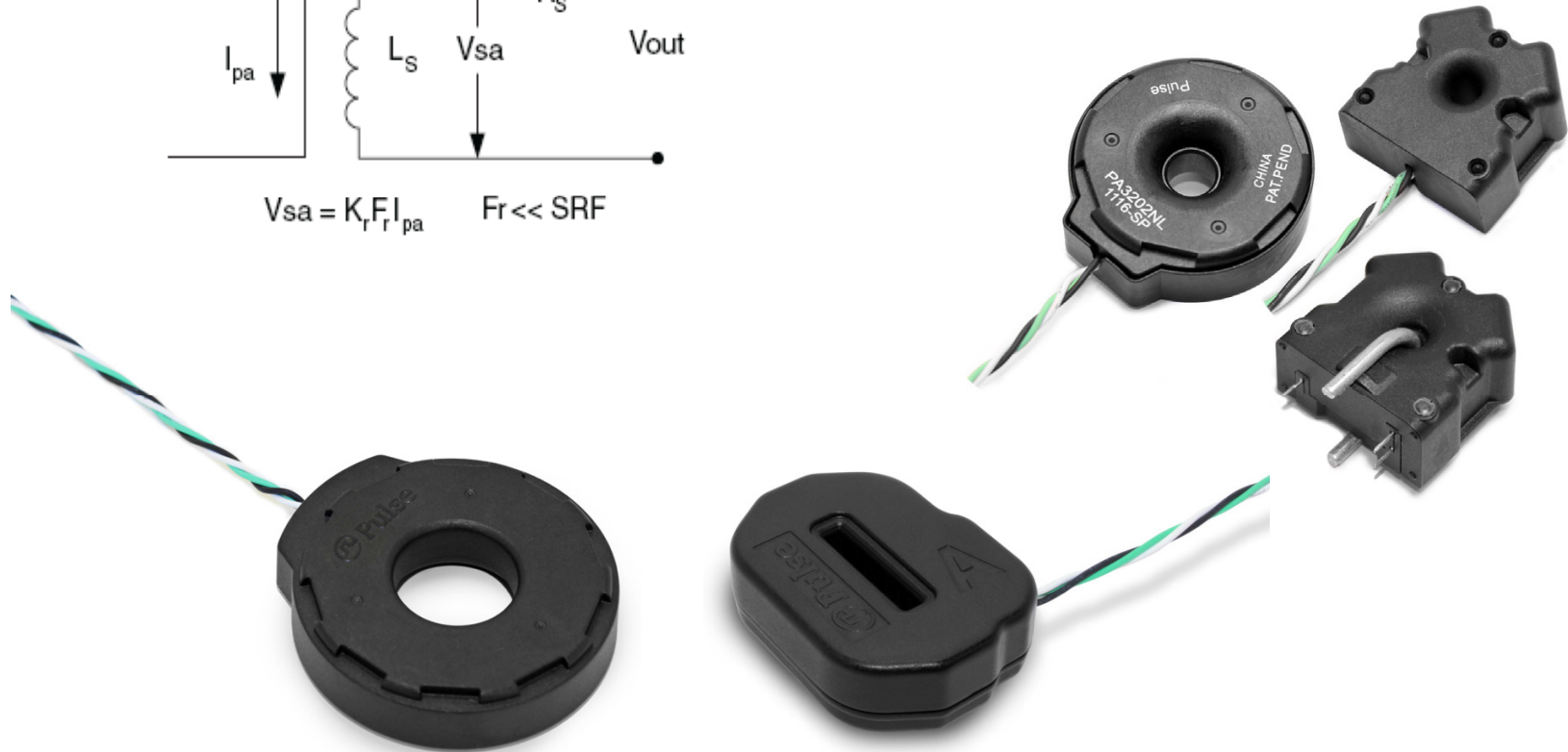
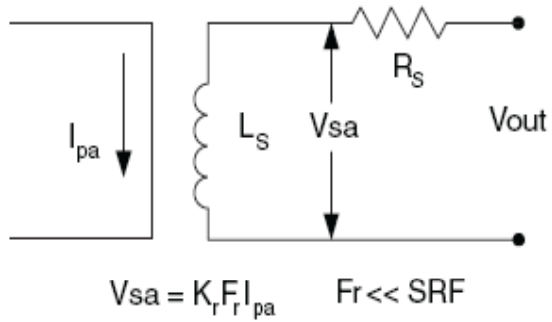

# Sidewinder Application Notes

- Black wire is connected to the Current Plus pin I+
- Connect the White wire and the Green wire together, and then connect them to the Current Negative pin, I-
- No burden resistor is required
- Requires an IC that supports Rogowski Coils

Vendor	IC Families
Accent	AMS201, AMS231
Analog Devices	ADE7753, ADE7878
Atmel	ATM90Exx
Cirrus Logic	CS5484, CS5490
IDT	90E32, 90E36

Vendor	IC Families
Maxim Integrated	71M6531, 71M6533
Renesas	RX21A
ST Micro	STPM01
Texas Instruments	MSP430FE42xA

# Contact Information

---

More information is available at

[www.PulseElectronics.com/Sidewinder](http://www.PulseElectronics.com/Sidewinder)

Contact Glenn Roemer at

email: [groemer@pulseelectronics.com](mailto:groemer@pulseelectronics.com)



*Content is subject to change without notice  
©2011 All Rights Reserved*

